

TITLE

INSPECTION AND REPLACEMENT OF NOSE GEAR DRAG LINKS

EFFECTIVITY**MODEL**

Lancair IV, IV-P, IV-PT, and Legacy

SERIAL NUMBERS

ALL

REVISION AND ISSUE DATE

REV #	DATE	DESCRIPTION	APPROVED BY
IR	5/04/2018	Initial Revision	E.W. King III

1. SUBJECT

- 1.1** Investigation into the cause of a recent retraction of a Lancair IV-P nose gear after a normal landing indicated abnormal wear in the scissor link over-center pivot joints. The subject parts are referred to as the Overcenter Link Assy. (one part) and lower drag links (two parts) in the Lancair build manuals. This aircraft incorporated the Lancair improved drag link parts with bronze bushings, however they were installed with incorrect hardware and improper torque specifications causing abnormal wear of the links and bronze bushings. This wear caused the scissors over-center feature to be disabled, allowing the gear to retract when the nose wheel touched the runway.
- 1.2** This Service Bulletin (SB) describes action required by operators of aircraft in the field.

2. COMPLIANCE

- 2.1** Inspection: Perform inspection described in Section 6.

3. COST

- 3.1** Estimated labor associated with inspection only is one (1) man-hour. Estimated labor associated with lower drag link replacement is three (3) hours.

4. LOCATION

- 4.1** Replacement of the drag links and hardware can be accomplished at any appropriately certificated agency, certificated person or Repairman.

5. CONTACT

- 5.1 For additional information regarding the inspection or to make arrangements to purchase a drag link upgrade kit, please contact:

Lancair International, LLC
122 Howard Langford Drive
Uvalde, TX 78801
Phone: (830) 423-3005, Ext. 703
E-mail: sales@lancair.com

6. INSPECTION

- 6.1 Determine if the aircraft is equipped with the original or improved design lower drag links. The original upper and lower drag links were joined by two pivot bolts with cotter-pinned castle nuts that allow them to pivot on the bolts during gear retraction (Figure 1). The improved lower drag links added a bronze bushing to each of the lower drag links at the center pivot point (Figure 2). The bronze bushings are designed to be securely bolted to the upper drag link so that the pivot point becomes the interface between the new bushings and the lower drag links.

- 6.2 Visually inspect the lower drag link installation as follows:



Figure 1
Original Design Lower Drag Links



Figure 2
Improved Design Lower Drag Links

WARNING: When performing this inspection and drag link replacement, ensure that the nose of the aircraft is properly lifted, secured and shored to prevent the nose of the aircraft from collapsing to the ground which can cause damage, injury or even death. An engine hoist secured to the lifting ring on the engine is best for lifting the nose wheel off the ground.

- 6.2.1** Aircraft equipped with the original steel-on-steel pivots (without the bronze bushings) will have a bolt with a castle nut and it is secured with a cotter pin.
- 6.2.1.1** Using a straightedge, check that the drag links are over-center shown in Figure 3. There is no "over-center distance" specified, but a range from $\frac{1}{4}$ " to $\frac{1}{2}$ " as measured from the centerline of the pivot bolt joining the upper and lower links is ideal.

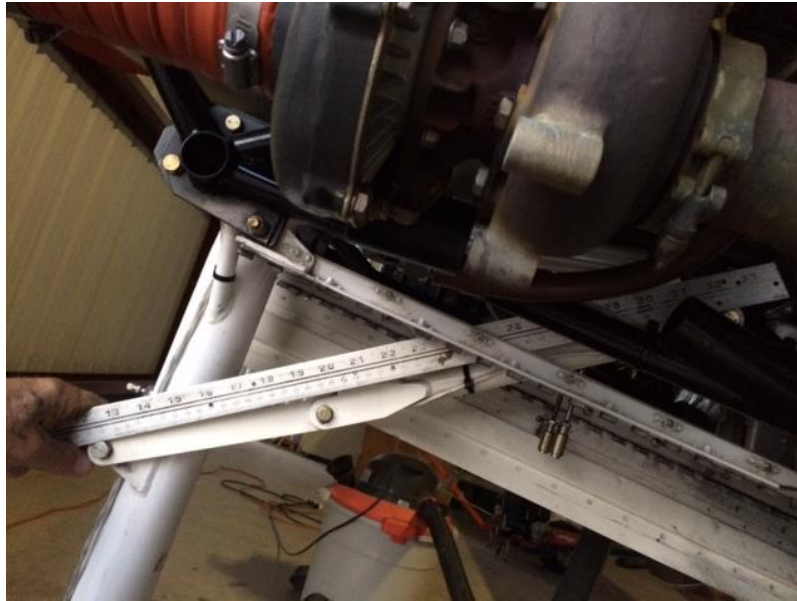

Figure 3

- 6.2.1.2** With the hydraulic pressure zeroed, remove the emergency extension gas spring. It is easier if you first remove the long bolt connecting the nose strut to the lower drag links per the Lancair assembly manual instructions.
- 6.2.1.3** With the gas spring disconnected and the nose wheel off the ground, apply fore/aft force to the nose wheel, and observe any movement of the pivot point between the upper and lower drag links. Any amount of wear in the pivot joints between the drag links will cause the joint to move when fore/aft pressure is applied to the nose wheel because the steel-on-steel contact point between the ears of the lower drag links and the upper link acts as the initial pivot point for the assembly. If wear in the joint is sufficient to allow it to move over-center as measured in step 6.2.1.1 above, the nose gear is restrained from retracting at touchdown only by the combined hydraulic and gas spring pressure. If either fails, the nose gear could retract upon a normal touchdown.

- 6.2.1.4** If the above test indicates the drag link pivot point moves past, or close, to the over-center position, replacement of the drag link assembly is dictated. Once this joint develops free play, the wear rate will increase exponentially until it fails.
- 6.2.1.5** In most cases, replacement of the two lower drag links with the improved design lower drag links and the correct installation of the new hardware between the upper and lower links will correct this problem. If the holes in the upper overcenter link have been worn excessively, replacement of this part is also indicated.
- 6.2.2** If your aircraft is equipped with the improved design lower drag links inspect to ensure that the proper hardware is installed. Perform the procedure shown in Step 6.2.1.1 thru 6.2.1.5. The hardware should consist of the proper tension bolts and self-locking steel nuts torqued to 90-100 in/lbs. It is not acceptable for these bolts to turn with less than the specified torque applied.
- 6.2.3** Other recommended checks that can be performed at this time:
- 6.2.3.1** With the gas spring and hydraulic actuator disconnected, check for free swing, without binding, of the upper strut pivot points from full extension to full retraction. Any binding is cause for further investigation.
- 6.2.3.2** With the gas spring and hydraulic actuator disconnected, check the side to side movement of the upper strut in the pivots. Any movement greater than 0.01" should be corrected by shimming the bearing mounting blocks per the Lancair assembly manual. Side to side play at this pivot contributes to nose wheel shimmy.

7. SERVICE / ACTION

- 7.1** The original upper and lower nose gear drag links were joined with a drilled bolt and castellated nut that permitted the links to pivot on the bolt. The improved lower drag links being provided REQUIRE the two drilled bolts/castellated nuts that served as the center drag link pivot be replaced with tension bolts and locking nuts. This serves to make the two lower drag struts pivot on the new bushings provided, rather than on the attachment bolts. We strongly recommend you not re-use the original bolts because they are likely worn and may not provide the needed security for the bronze bushings being clamped to the upper drag link.

7.2 Procedure (See Figure 2 and 4):

- 7.2.1** Lubricate lightly and install each 4722 Bronze Bushing in one of the new 433-0001 Lower Drag Links.
- 7.2.2** Ensure the small diameter of the 4722 Bushing protrudes a minimum of 0.035" beyond the flat face of the lower drag link.
- 7.2.3** With the large diameter of the 4722 Bushing on the inside face of the 433-0001 Lower Drag Link, install the new lower links to the overcenter link using NEW AN4-11A Bolts (head on inside face of 4722 Bushing), AN960-416 Washers and AN363-428A Steel Lock Nuts.
- 7.2.4** Before attaching the 4722 Lower Drag Links to the nose strut, torque the above bolts to 90-100 in./lb and ensure each of the two lower links will pivot on the upper link through the full range of movement required during gear retraction. Do not continue re-assembly until this condition is satisfied for both lower links. This may require removal of paint from the mating surfaces.

Note: The Overcenter Link Assembly has been upgraded to a stronger part by SB074-0111. If you have not complied with this service bulletin, it is recommended that SB074-0111 be incorporated at this time.

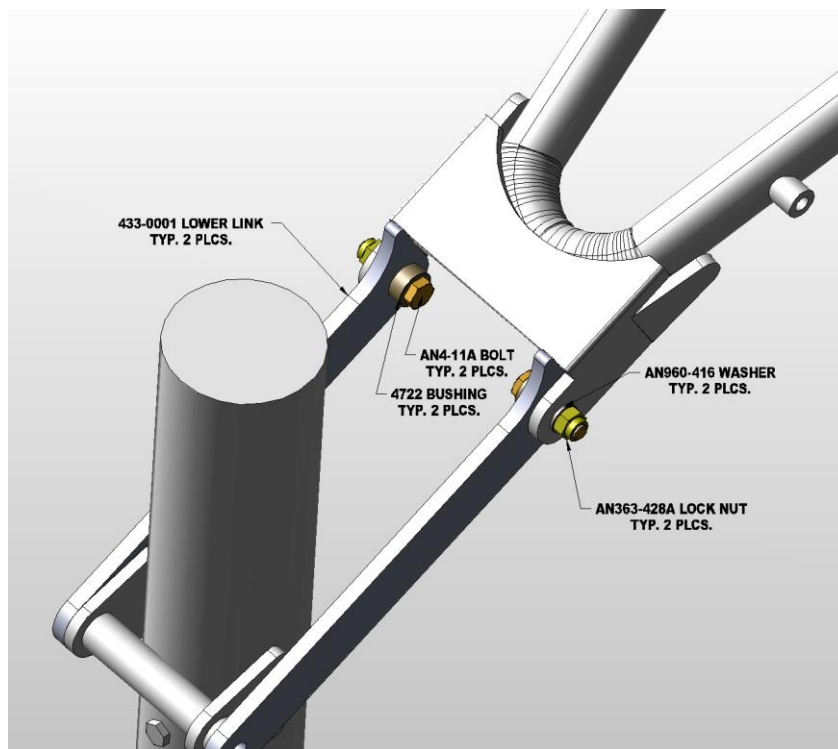

Figure 4

SERVICE BULLETIN

- 7.3** The following kit is necessary for all airplanes when incorporating SB077-0518.

MATERIAL - Cost and Availability

PART NUMBER		AVAILABILITY		COST
SB077-01		*		*

NEW P/N	QTY.	NOMENCLATURE	OLD P/N	INSTRUCTIONS/ DISPOSITION
SB077-01	1	Kit , consisting of the following parts:		
433-0001	2	Lower Drag Link	GM027-4	Discard
4722	2	Bronze Bushing	N/A	N/A
AN4-11A	2	Bolt	AN4-7	Discard
AN960-416	2	Washer	AN960-416	Discard
AN363-428A	2	Nut	AN310-4	Discard

* Please contact Lancair Parts for current cost and availability of parts listed in this service bulletin. Phone toll free 1-866-LANCAIR or 1-830-423-3005. Send Email to: sales@lancair.com.

Based on availability and lead times, parts may require advanced scheduling.



SERVICE BULLETIN SB077-0518

Record of Compliance

Please record findings associated with this SB, including zero defects to:

Lancair International. LLC
122 Howard Langford Drive
Uvalde, TX 78801
Phone: (830) 423-3005, Ext. 710
E-mail: chip@lancair.com

Aircraft Owner: _____

Aircraft Registration Number: _____

Aircraft Total Time: _____

Notes and Findings:

Report Submitted By: _____ Date: _____