

CHAPTER 21 REVISION LIST



The following list of revisions will allow you to update the Lancair ES construction manual chapter listed above.

Under the "Action" column, "R&R" directs you to remove and replace the pages affect by the revision. "Add" directs you to insert the pages shown and "R" to remove the pages.

Page(s) affected	Current Rev.#	Action	Description
21-1	6	R&R	Added section P.
21-2 thru 21-71	0	None	
21-72	6	R&R	Removed text at bottom of page.
21-73 thru 21-79	6	Add	Add section P.



21-i

Chapter 21

6/4-1-99

ENGINE INSTALLATION- LYCOMING



CHAPTER 21: ENGINE INSTALLATION - LYCOMING



REVISIONS

From time to time, revisions to this assembly manual may be deemed necessary. When such revisions are made, you should immediately replace all outdated pages with the revised pages. Discard the out dated pages. Note that on the lower right corner of each page is a "revision date". Initial printings will have the number "0" printed and the printing date. All subsequent revisions will have the revision number followed by the date of that revision. When such revisions are made, a "table of revisions" page will also be issued. This page (or pages) should be inserted in front of the opening page (this page) of each affected chapter. A new "table of revisions" page will accompany any revision made to a chapter.

Arrows

Most drawings will have arrows to show which direction the parts are facing, unless the drawing itself makes that very obvious. "A/C UP" refers to the direction that would be up if the part were installed in a plane sitting in the upright position. In most cases the part shown will be oriented in the same position as the part itself will be placed during that particular assembly step. However, time goes on and changes are made, so careful attention should be paid to the orientation arrows. That old cartoon of the guy agonizing over the plans for his canoe, built one end up, one end down, should not happen in real life. Especially to you.

CONTENTS

1. INTRODUCTION
2. DRAWING LIST
3. EQUIPMENT REQUIRED - SPECIAL PARTS, TOOLS & SUPPLIES
 - A. PARTS
 - B. TOOLS
 - C. MATERIALS & SUPPLIES
4. PROCEDURE
 - A. FIREWALL PREPARATION
 - B. MOTOR MOUNT ATTACHMENT
 - C. NOSE GEAR, FINAL INSTALLATION
 - D. NOSE GEAR BOOT
 - E. FUEL SYSTEM (FIREWALL FWD)
 - F. MOUNTING THE ENGINE
 - G. COWLING INSTALLATION (LOWER COWL)
 - H. COWLING INSTALLATION (UPPER COWL)
 - I. ENGINE BAFFLING
5. LYCOMING 0-320 AND IO-320 ENGINE BAFFLING INSTALLATION
 - A. ALUMINUM BAFFLE PLATES
 - B. SPARK PLUG WIRE GUIDES
 - C. RUBBERIZED SEALING STRIPS
 - D. SILICONE SEALING
 - E. OIL COOLER AIR LINE
 - F. MAGNETOS
 - G. REMOTE OIL COOLER MOUNTING
 - H. SPARK PLUG LEADS
 - I. EXHAUST SYSTEM
 - J. CABIN HEAT SYSTEM
 - K. AIR INTAKE SYSTEM (ENGINE)
 - L. PROPELLER INSTALLATION, CONSTANT SPEED
 - M. PROPELLER INSTALLATION, WOOD, FIXED PITCH
 - N. SPINNER
 - O. TACHOMETER
 - P. MISCELLANEOUS PAPERWORK

LANCAIR® 320FB

21-1

Chapter 21	REV.	6/04-01-99
ENGINE INSTALLATION - LYCOMING		



1. INTRODUCTION

The engine installation, when completed, may tend to look rather complicated but it is actually quite simple when taken one step at a time. The scope of this chapter does not include educating the builder on all the disciplines learned by an A&P mechanic, it is advised that you at least have one inspect and approve your installation prior to any flight attempts.

NOTE: The book: "Firewall Forward" by Tony Bingelis is available from the EAA in Oshkosh (1-800-843-3612), and is highly recommended for the non A&P builder. It would be most beneficial to read it cover to cover before proceeding with this chapter.

This chapter will cover the following systems/installations in the order listed: Firewall preparation, Fuel system, Nose Gear Boot, Cowling Installation, Engine Baffling Installation, Oil Cooler, Spark Plug Leads, Exhaust pipes, Cabin Heat System, Fuel Injector Control Cables, Fresh Air / Filter Air-Box / Valves, Propeller, Spinner, Magnetos, and Tachometer. Keep in mind that this is undoubtedly the world's tightest crossover exhaust system, and equally tightly cowled. The positioning and clearances of all items under the cowling must be thought through in an integrated manner, before any one item is positioned to avoid a domino effect of problems. Read this chapter start to finish, before starting the installation.



2. Drawing list

Figure	Page	Title
21-1	21-7	Firewall layout
21-2	21-8	Firewall grommet installation
21-3	21-9	Control cable layout
21-4	21-10	Motor mount installation
21-5	21-13	Nose gear boot
21-6	21-14	Pattern for nose gear boot construction
21-7	21-15	Nose gear boot construction
21-8	21-15	Boot cover plate
21-9	21-16	Nose gear boot installation
21-10	21-17	Firewall fuel connection
21-11	21-18	Gascolator installation
21-12	21-20	High pressure "fuel injection" boost pump installation
21-13	21-21	Engine driven fuel pump, plumbing
21-14	21-24	Dynafoal engine mount
21-15	21-25	Engine mounting biscuits
21-16	21-26	Cowling pre-fitting trim requirements
21-17	21-28	Cowl fitting
21-18	21-30	Trimming the air inlet flange on the lower cowling
21-19	21-31	Firewall flange build up
21-20	21-32	Cowling attachment screws
21-21	21-34	Engine baffling assembly
21-22	21-37	Center cylinder baffling
21-23	21-39	Securing lower edge of cylinder plates
21-24	21-40	Lycoming 320 baffling
21-25	21-41	Plug wire guides
21-26	21-46	Typical oil cooler installation, forming scat tube attachment
21-27	21-47	Baffling flex seal
21-28	21-50	Shroud, oil cooler
21-29	21-50	Baffling, flange - remote oil cooler
21-30	21-53	Cabin heat valve
21-31	21-57	Air box construction
21-32	21-58	L320 shroud configurations
21-33	21-59	Remote filter air box assembly
21-34	21-60	Typ. ram/filtered air install. for front-mounted fuel injection
21-35	21-61	Ram airbox, with both carb heat and filtered air
21-36	21-66	Propeller extension / prop / spinner assembly
21-37	21-68	Spinner cutout
21-38	21-70	Hartzell 2 blade spinner cut-out template
21-39	21-71	Hartzell 2 blade prop and spinner assembly
21-40	21-72	Mechanical tachometer location



3. Equipment required

A. Parts

- Motor mount
- AN-723A bolts (4)
- AN365-720 nuts (4)
- AN365-1032 bolts (4) for mounting gascolator
- AN3-xxA nuts (4) for mounting gascolator
- AN816-6D fitting for gascolator
- AN822-6 fitting for gascolator

OPTIONAL PARTS:

Item Description	Source
Lycoming engine, NEW! - - - - -	N
Spinner & Backup Plate - - - - -	N
Prop, Hartzell & MT constant speed - - - - -	N
Prop Governor - - - - -	N, C
Cowl Scoop for fuel injected / Carbureted engines - - - - -	N
Tinnerman washers - - - - -	N, C
Baffling Kit, aluminum & flex seal - - - - -	N
Nose Gear boot - - - - -	N
Control Cable, Throttle (friction lock) - - - - -	N, C
Control Cable, Mixture (ratchet)- - - - -	N, C
Control Cable, Prop Gov. (vernier) - - - - -	N, C
Control Cable, Cabin Heat - - - - -	N, C
Control Cable, Air Selector (ratchet) - - - - -	N, C
Cabin Heat Valve - - - - -	N, C
Gascolator - - - - -	N, C
Fire Shield Tube covering- - - - -	N, C
Zip Ties, 2" dia. - - - - -	C
Scat Ducting, 1-1/2" dia. - - - - -	C
Scat Ducting, 3" dia. - - - - -	C
Hose Clamps, stainless, 4" dia. - - - - -	C
Hose Clamps, stainless, 2" dia. - - - - -	C
Oil Cooler, 9 vane - - - - -	C
Shroud-fiber glass, Oil Cooler - - - - -	U
Shroud-fiber glass, Air Filter - - - - -	U
Air Filter - - - - -	U, C
Electric boost pump - - - - -	N, C
Exhaust system - - - - -	N

C = Catalog Supplier, such as Aircraft Spruce & Specialty 1-800-824-1930

N = Neico, 1-503-923-2244

U = Owner fabricated



- B. Tools
Drill motor
Assorted drill bits:
 3/4"
 13/16"
 7/16"
 7/8"
 1 1/2"
Level
Assorted wrenches
Torque wrench
Cleco pliers and about 6 clecoes or equiv.



C. Materials and supplies

	QTY	
Assorted grommets:		
AN931-4-12, 1/4" I.D.	1	
AN931-9-13, 9/16" I.D.	1	
AN931-4-7m, 1/4" I.D.	1	
AN931-4-7, 1/4" I.D.	2	
Fiberfrax scraps		
Stainless stl scraps from firewall		
High temp silicone		
Sheet metal screws	6	(for mounting nose gear boot)
Hose clamp for nose gear boot		
Solid and flexible fuel line and fittings to match your particular fuel system (See figure 21-12 for typical installations)		
#20 gauge wire for wiring magnetos, with appropriate connectors.		
Assorted grit sandpapers		
Micro		
Safety wire		
BID material		



4. **Procedure**
 A. **Firewall preparation**

These procedures, which have been covered in previous chapters, will need to be completed before proceeding with this chapter; refer to chapter 11, page 11, for the installation of the firewall flange. Refer to chapter 5, page 5-36, for the installation of the Fiberfrax/Stainless Steel Firewall (be sure to save the firewall leftovers, they are used in this chapter for shielding). Refer to chapter 5 for the installation of the Motor Mount and Nose Gear.

Before mounting the engine, it is best to first locate and drill the access holes for cables, wires, etc. Mark the location of the holes and items (gascolator, volt reg., etc.) You may find it helpful to temporarily install the Motor Mount and tape the firewall items in place to work out the best placement that is free of interference.

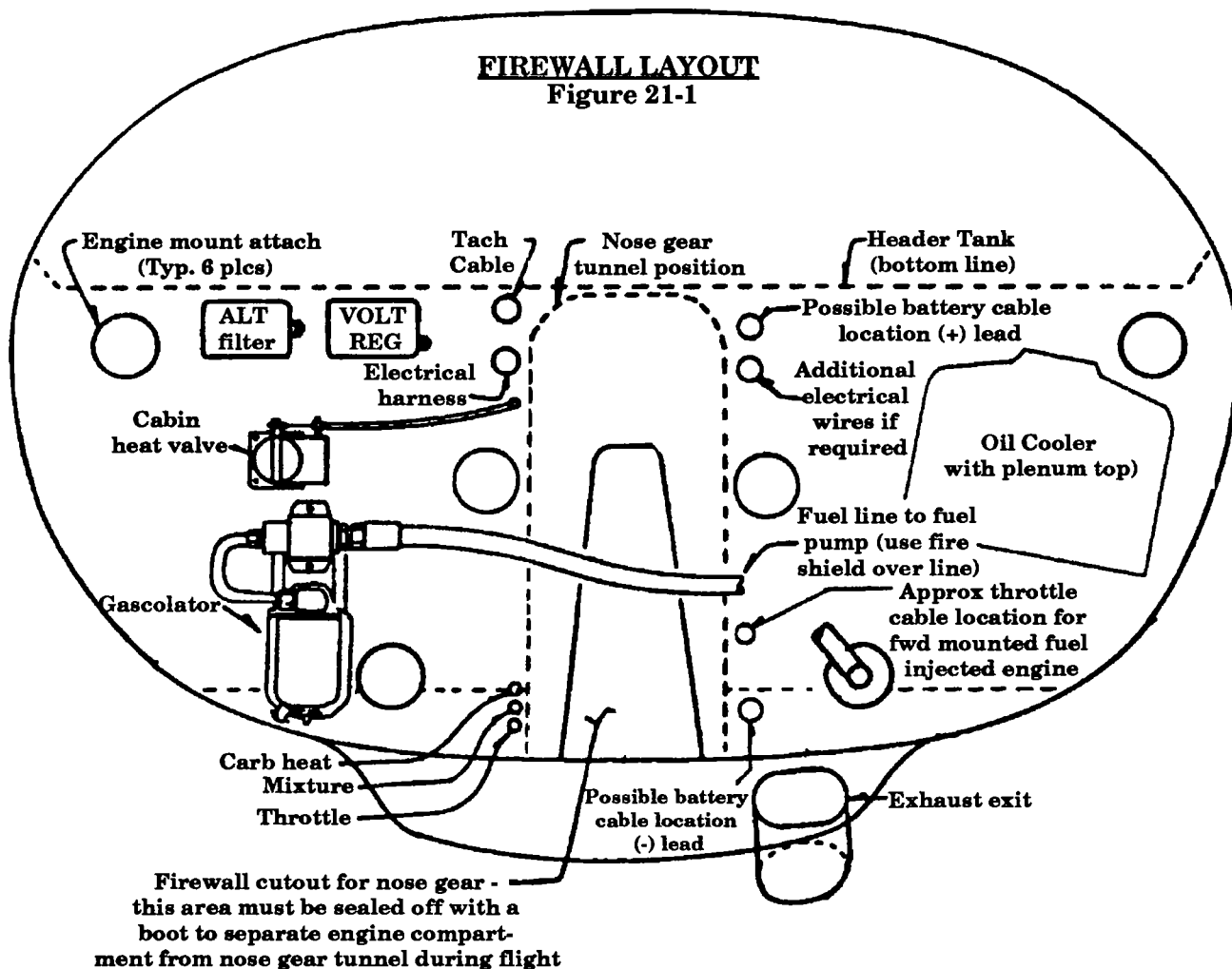

1. Per figure 21-1 locate all through holes. There are many ways to route items through the fire wall, this is simply one possible approach that does work. All through holes must be sealed and you must also protect the cables and wires from chafing etc. A rubber grommet will usually work well, it can be installed in two different manners, see figure 21-2. A small dab of high temperature silicone will secure the grommets in position.
2. The recommended hole diameters are as follows:

ITEM	Hole Dia.	Grommet size
Tach Cable (mech)	3/4"	AN931-4-12, 1/4" I.D.
Electrical Harness	13/16"	AN931-9-13, 9/16" I.D.
Throttle Cable	7/16"	AN931-4-7m, 1/4" I.D.
Carb Heat Cable	7/16"	AN931-4-7, 1/4" I.D.
Cabin Heat Cable	7/16"	AN931-4-7, 1/4" I.D.
Gascolator	7/8"	NONE
Cabin Heat Valve	1-1/2"	NONE (Optional from Neico)
3. You will need a very sharp drill to get through the stainless steel on the firewall. For the larger holes, it is sometimes best to use a carbide cutter in a rotary tool to get through the stainless then drill on through with a standard drill bit.
4. The cabin heat valve may be installed on either the left or right side of the firewall.

FIREWALL GROMMET INSTALLATION

Figure 21-2

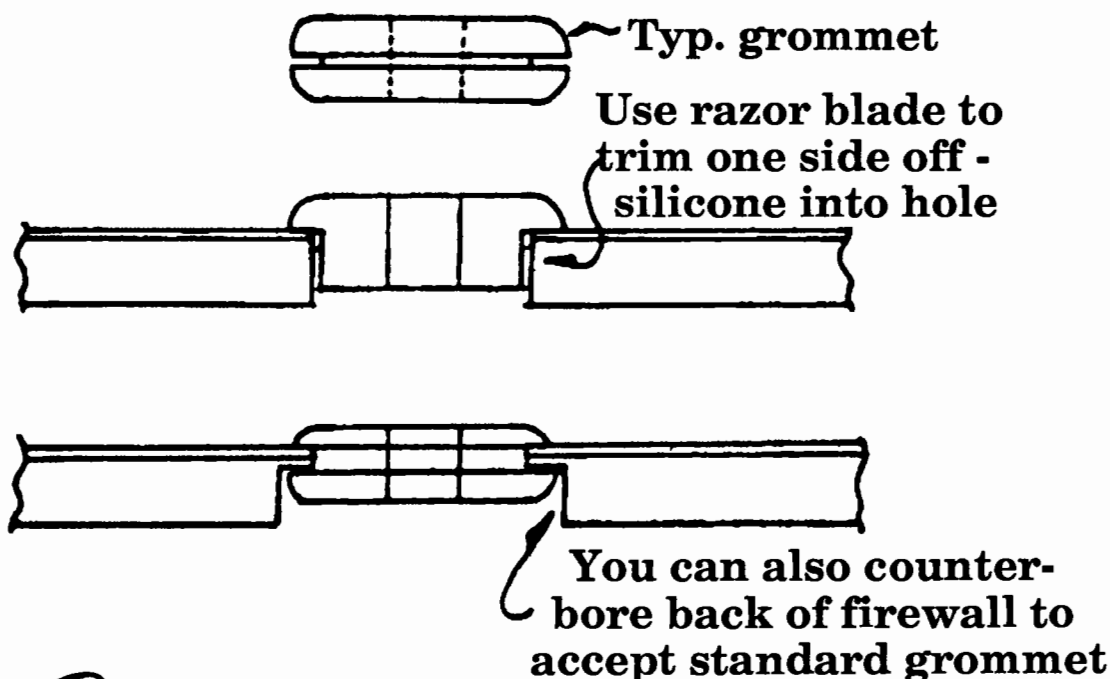

CONTROL CABLE LAYOUT

Figure 21-3

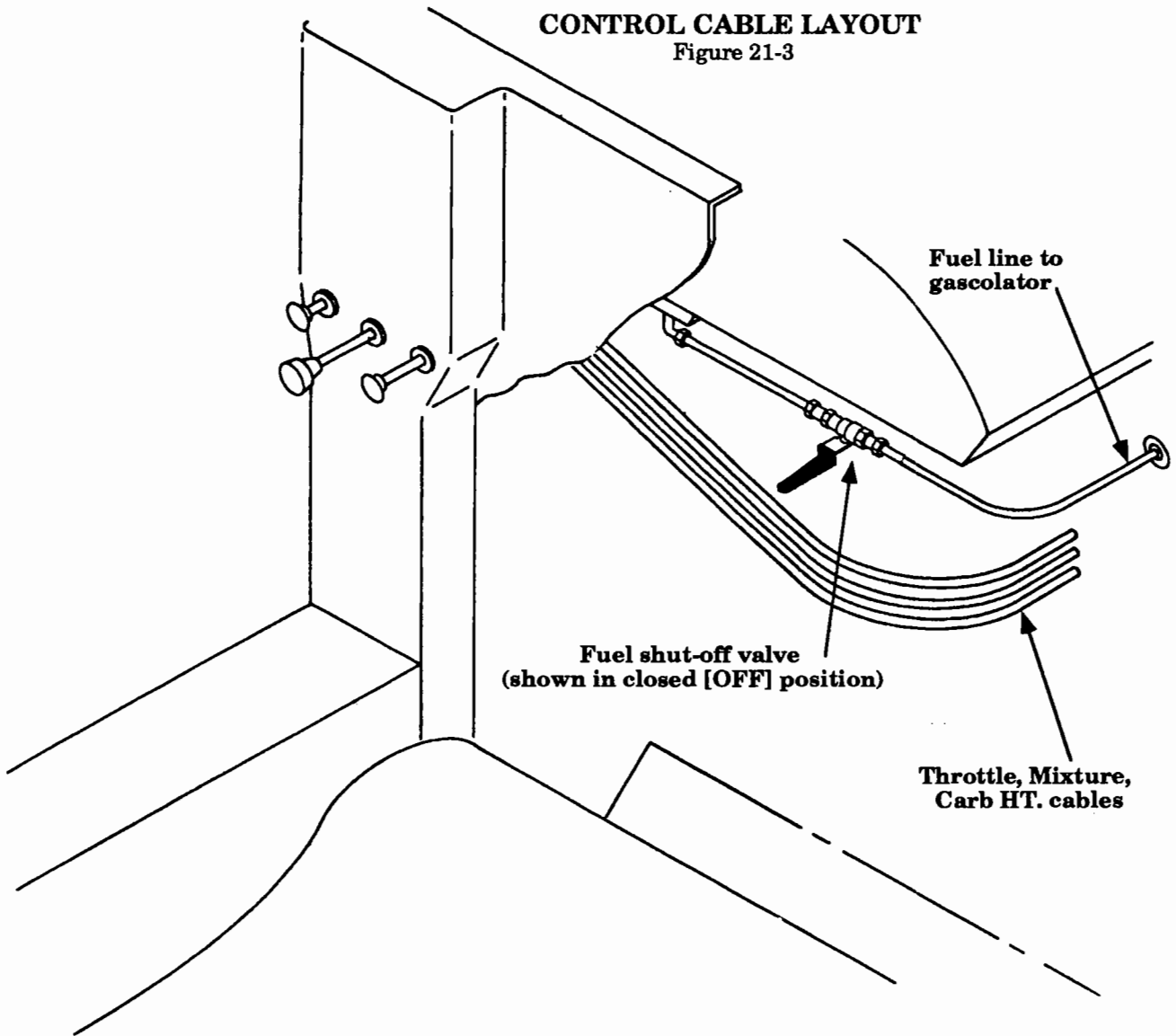

Fuel line to gascolator

Fuel shut-off valve (shown in closed [OFF] position)

Throttle, Mixture, Carb HT. cables

B. Motor mount attachment

1. Be sure the fuselage is level, check the level of the top left and right hole marks (ignore the center one for now). If they are not level with each other, cover old line with tape so as not to get confused. Be sure to leave the hole mark exposed, use a level as a straight edge and pivot on the lower of the two hole marks. Move the opposite end up or down to establish level and mark a new level line across the firewall, see figure 21-4. The markings on the firewall should however be correct. In actuality, $\pm 1/8"$ is perfectly acceptable.

MOTOR MOUNT INSTALLATION

Figure 21-4

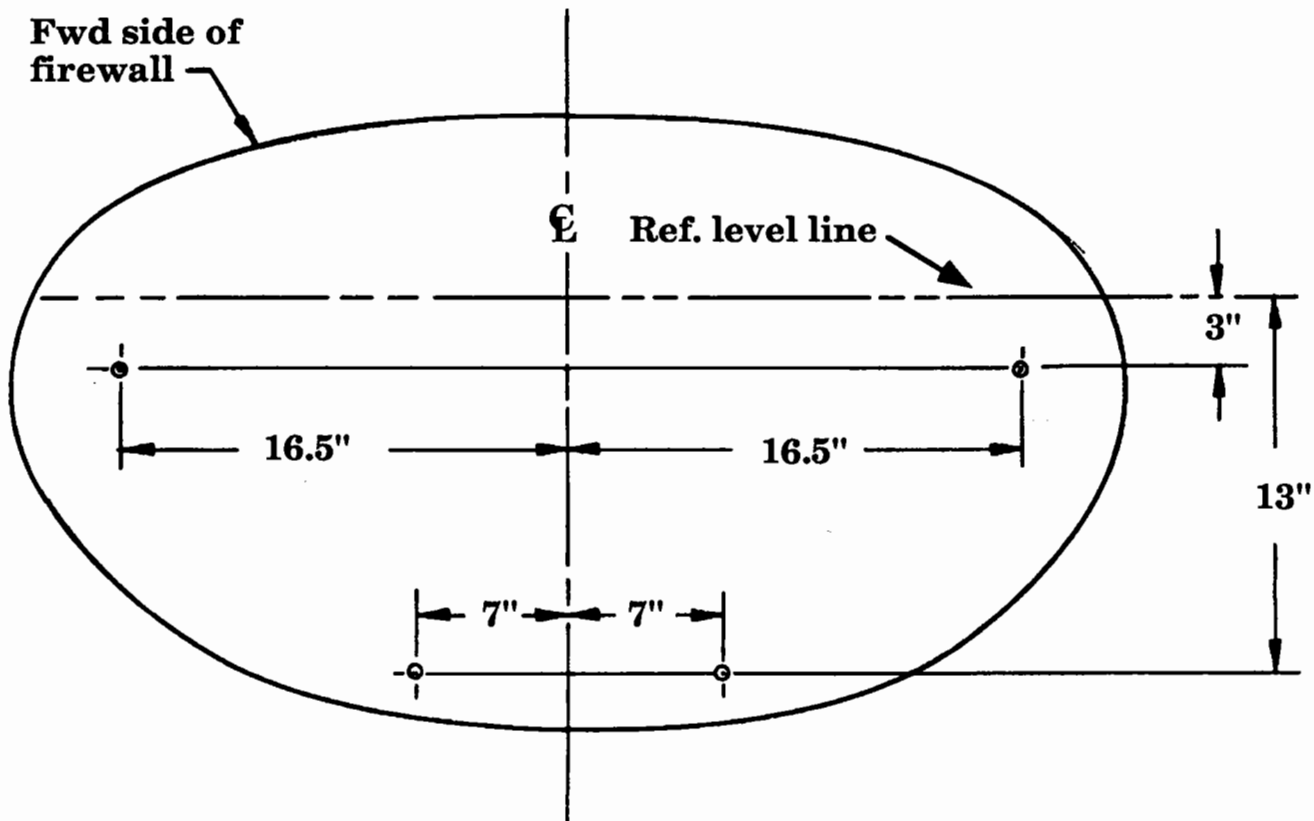

2. Using a 7/16" bit, drill through the firewall for the first attach bolt and bolt the mount to the firewall using one AN-723A/AN365-720 bolt/nut, loose enough to swing it up or down. Now align the center of the opposite side of the motor mount hole with the level line. Holding the motor mount firmly in place, use a 7/16" Dia. transfer punch or use the motor mount as a drill guide and drill through the firewall. (The nylock nuts must be on the aft side of the fslg).

3. Bolt through this hole in the same manner as the first. Tighten both bolts, Now the remaining mount holes can be drilled and bolted in position. We have demonstrated that bolting through the fiberfrax will work satisfactorily, however some builders have chosen to remove the fiberfrax directly under the mounting pads and add AN970-7 area washers. This will have the added appeal of a nice smooth stainless steel face sheet whereas bolting through the fiberfrax will tend to depress the stainless steel just a little. Thus, if so desired, use two washers in place of the fiberfrax under the stainless steel face sheet.



C. Nose gear, final installation

1. If you have not already installed / aligned the Nose Gear per chapter 5, then that must be done at this point.
2. Having completed the Nose Gear alignment and installation, perform the final cotter pinning / safety wiring / etc., as required.
3. If you have not ground tested your landing gear / hydraulic system per chapter 14, do it now before you get the motor in the way of easy access.
4. Be sure that all the wheels are securely blocked when proceeding on this installation.



21-12

Chapter 21

REV. 0 / 11-1-91

ENGINE INSTALLATION - LYCOMING



D. Nose gear boot

The nose gear cut out in the firewall will require a boot to seal the nose gear tunnel from the engine compartment. This close out boot should be made of stainless steel and lined on the aft side with a fireproof insulation such as fiberfrax or an equivalent.

1. Neico offers a stainless steel boot as an option, see figure 21-5, or fabricate one per figures 21-6 and 21-7. Use fiberfrax scraps from the firewall to line the inside of the boot, adhere it to the boot with high temp silicone.

NOSE GEAR BOOT

Figure 21-5

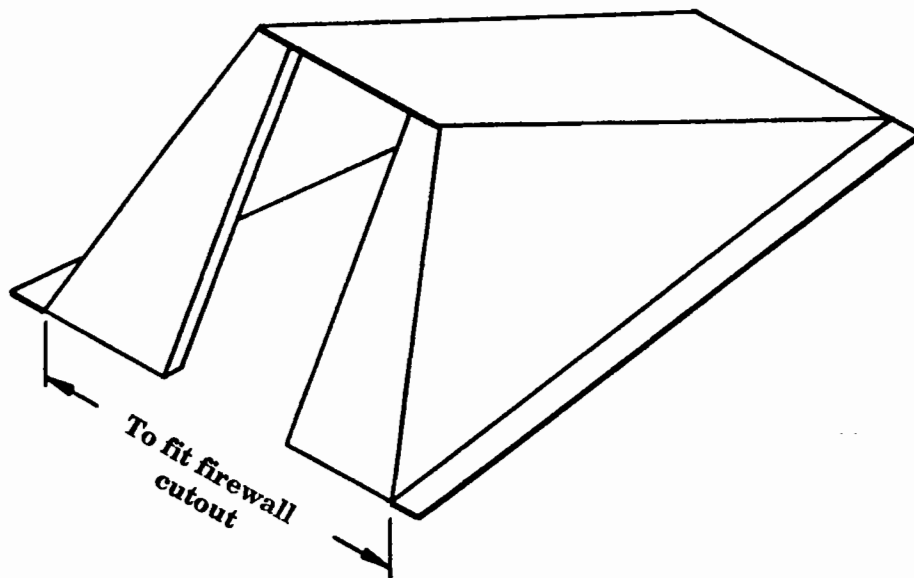

2. The boot should be mounted so that when the nose gear is fully retracted, the strut will fit relatively snug up to the top of the opening, see figure 21-8, however note that the boot also butts to the bottom of the firewall which is of first importance since the upper snug fit can be achieved with a secondary piece of stainless attached with pop rivets.

Mount the boot to the firewall with sheet metal screws, 3 per side. Use scrap firewall stainless steel and flexible high temp baffling material to make a boot seal that fits the contour of the top of the strut, attach this to the boot with sheet metal screws or pop rivets, see figure 21-8.

3. With the nose gear fully retracted, the open slot below the strut must be sealed as well. Again use scrap firewall stainless steel or .040" aluminum sheet and flexible baffling material to make a boot cover plate which clamps directly to the strut and fills the open slot in the boot when the gear is retracted, thus the entire nose wheel well area is fully sealed off, see figure 21-9.

PATTERN FOR NOSE GEAR BOOT CONSTRUCTION

Figure 21-6

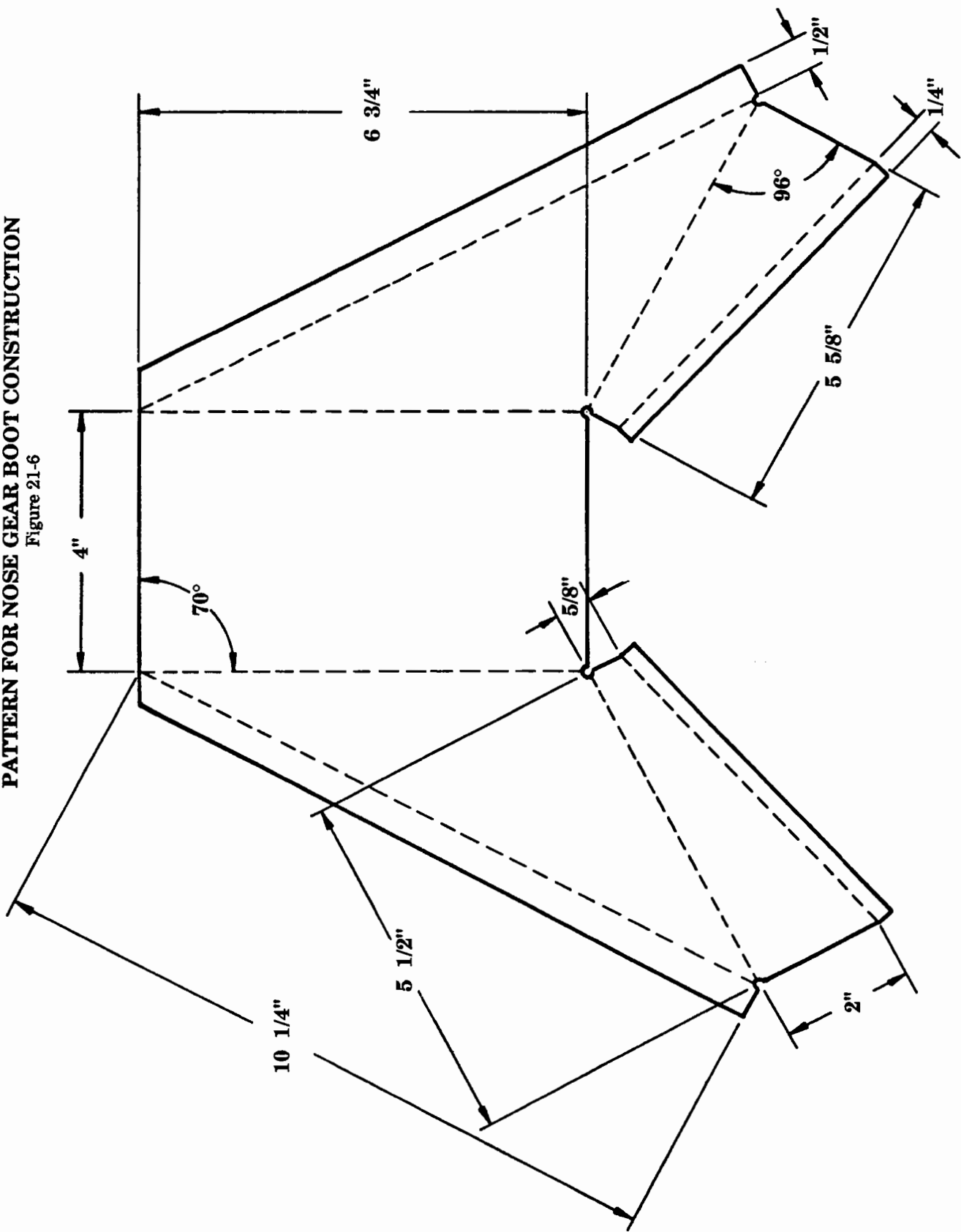

NOSE GEAR BOOT CONSTRUCTION

Figure 21-7

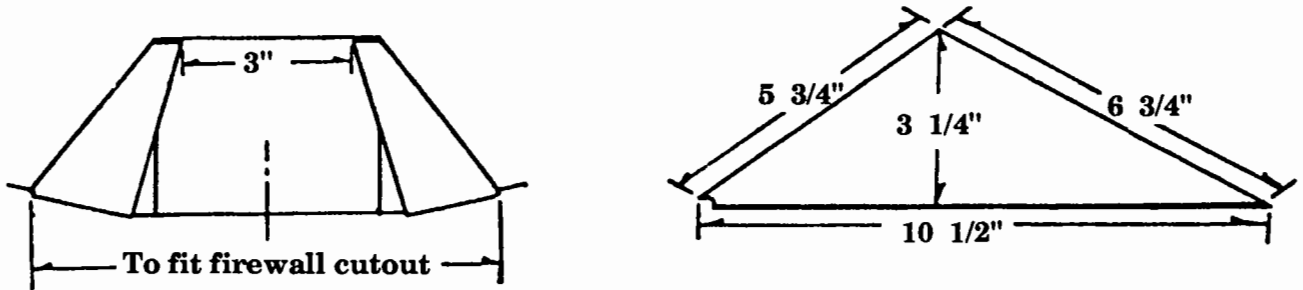

BOOT COVER PLATE

Figure 21-8

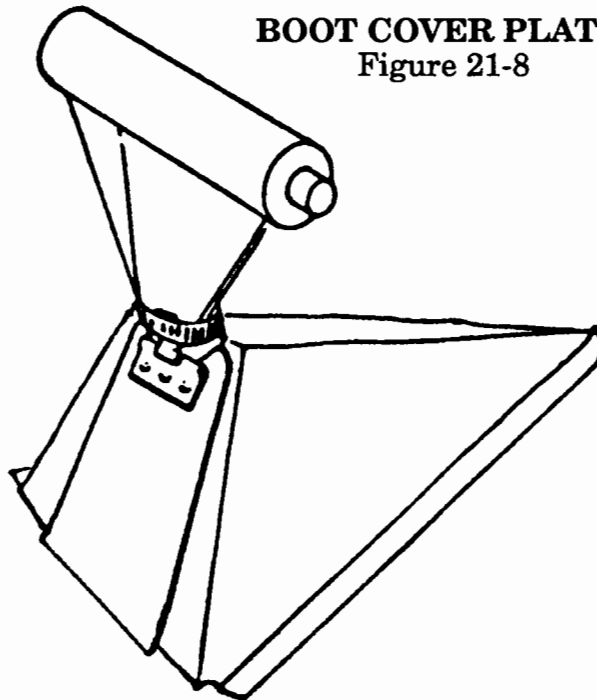

**NOSE GEAR BOOT INSTALLATION
SIDE VIEW**

Figure 21-9

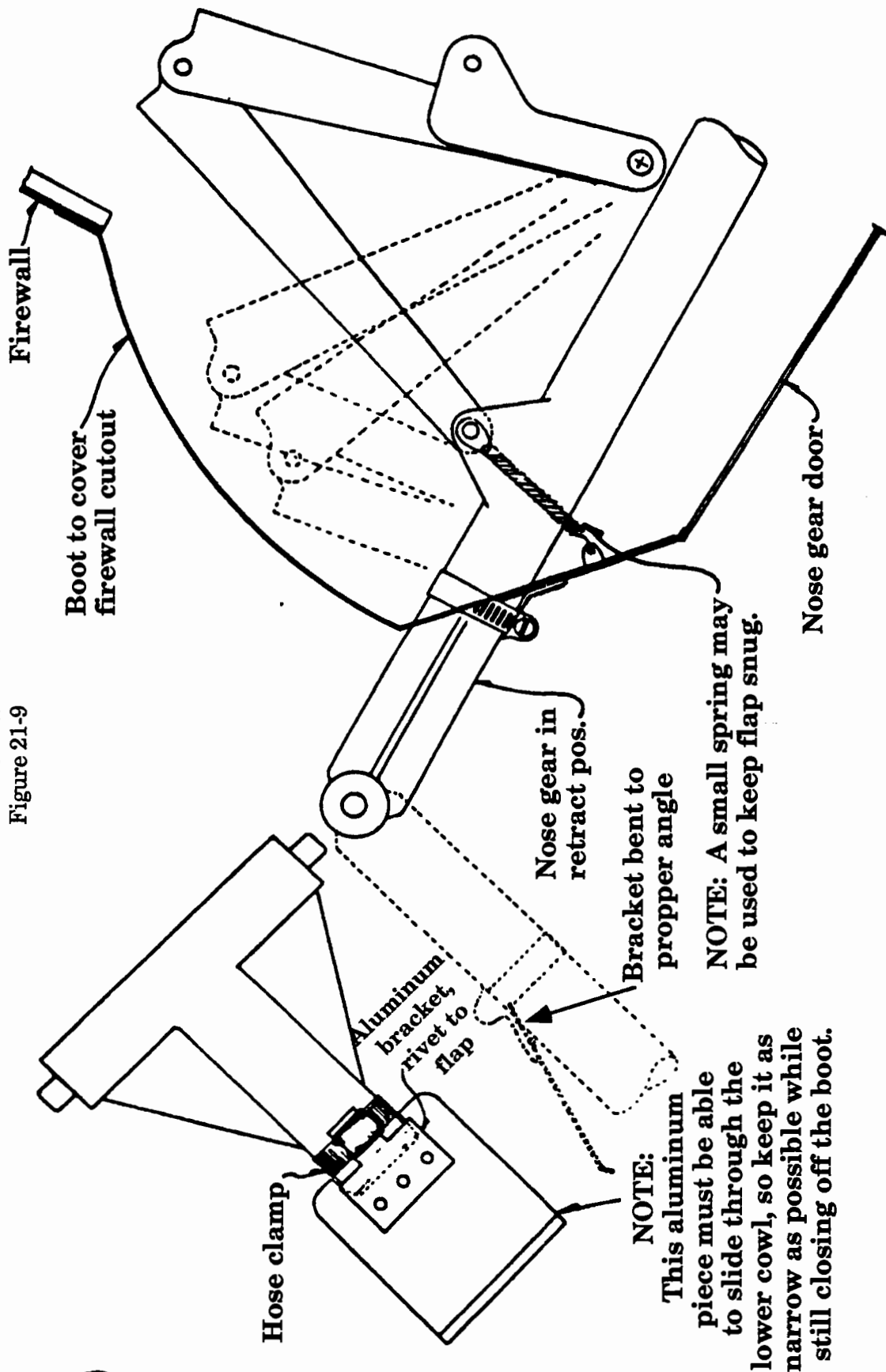

E. Fuel system (firewall fwd)

The fuel system is obviously critical to safe operations and thus the cause of a high percentage of accidents. Read the entire chapter before starting to work. Proceed slowly, with great care and attention to the smallest details.

Gravity feed, although technically possible with very low power settings, is NOT recommended since "head" pressures are at minimums and therefore the slightest disturbances can reduce flow to less than acceptable rates. An engine driven fuel pump is required with an electric boost pump as a backup.

The "Fuel System - Firewall AFT" was previously covered in chapter 11. As a rule of thumb, all fuel lines from the header tank fwd must be 3/8" aluminum line or -6 flex line. (The exception is with the fuel injected engines that use a dash-4 line from the engine driven pump to the injector and from the injector up to the divider head.) Smaller lines could deliver adequate amounts of fuel but the larger line reduces the tendency of clogs. The fuel line from the header tank line will pass through the shut off valve just downstream from the header tank line exit, then run fwd along the bottom of the header tank to the firewall, where the line turns 90° to run down the aft side of the firewall to connect to the gascolator fitting that protrudes through the firewall from the fwd side. Refer to figure 21-10.

Firewall fuel connection

Figure 21-10

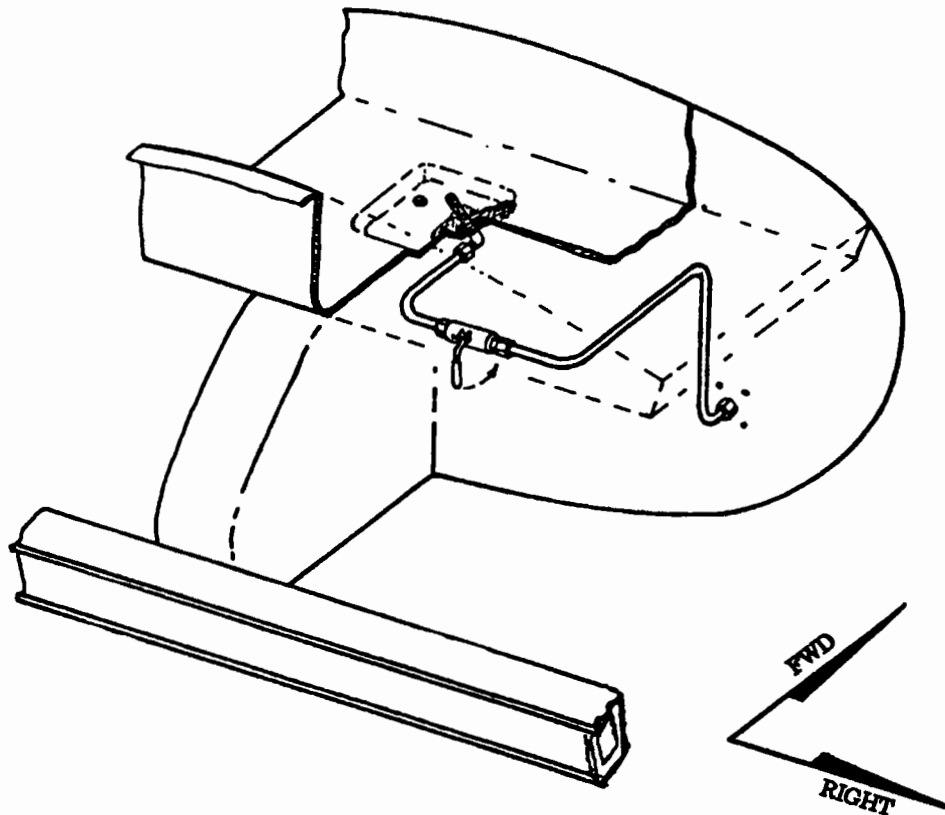

Gascolator Installation

Figure 21-11

SIDE VIEW

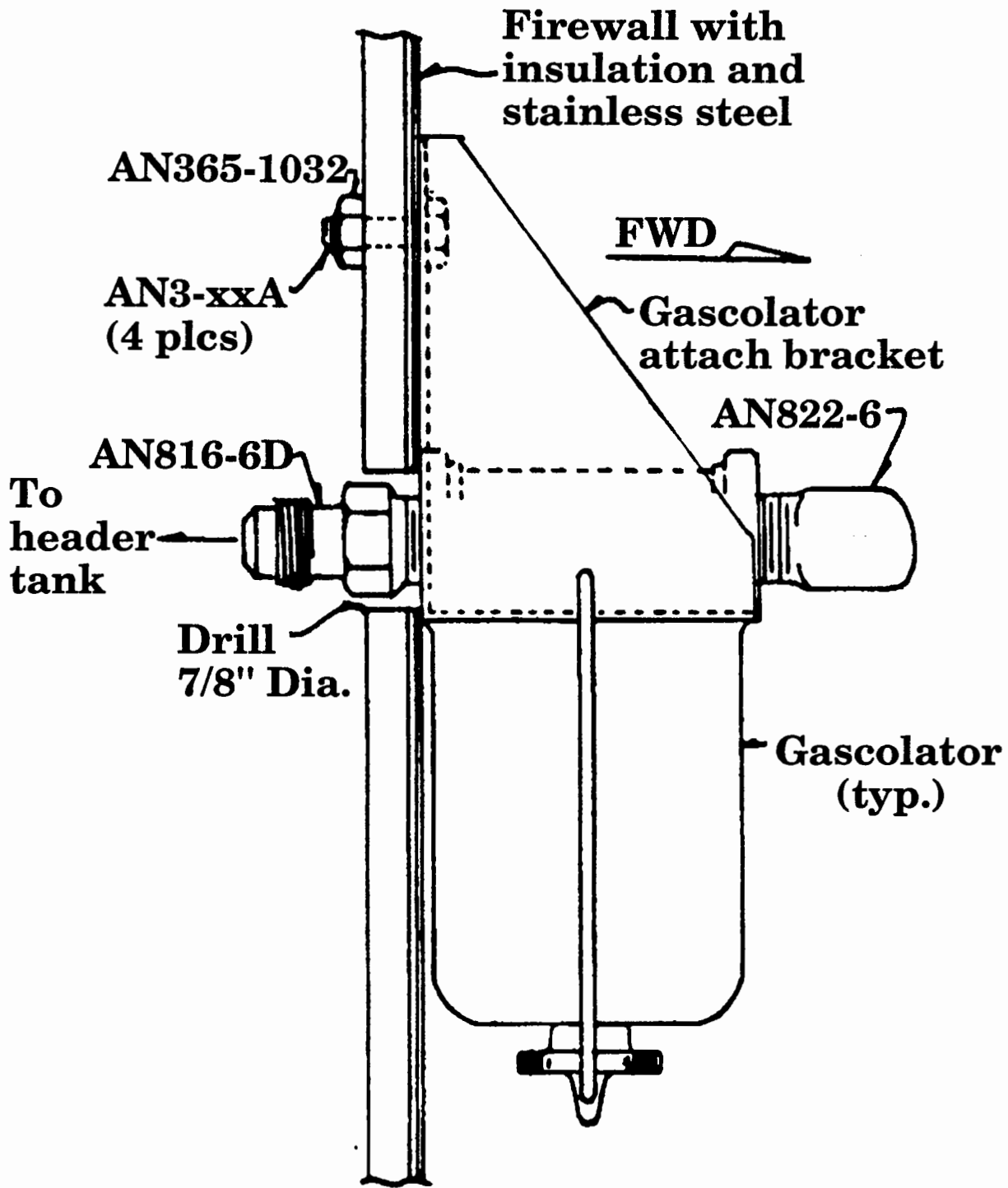

1. The gascolator (figure 21-11) is a final separator of contaminants before the fuel enters the carburetor (actually there is a last screen at the carb or injector body). The gascolator could be positioned slightly inboard of the location shown (see figure 21-1), between the lower engine mount attach point and the nose gear tunnel. This however crowds the throttle and mixture cables (if you have a carbureted engine) so the shown position is preferred. Access to the gascolator drain will be required. Either drill a small hole through the cowl at the appropriate location to insert a test tube sampler or (at the inbd location) angle the quick drain such that it can be reached from just aft of the lower cowl scoop from below (realize that this will require you to lay on your back and watch the spilled fuel run down your arm). If you have a gascolator with a remote cable operated drain (common in some Cessnas) be sure to position a drain line such that it drains well outside of the cowl, not into the cowl. Use a small aluminum line to run from the gascolator bowl to the cowl exit (approx. 3/16" dia. aluminum line depending on the exact type of gascolator selected. The *typical* end fitting required is the AN818-3D nut with AN819-3D sleeve and 3/16" 5052-0 aluminum tube).
2. Attach the gascolator with four (4) AN3 bolts to hold the support bracket. Use fire shield around the fuel lines everywhere inside the cowling. See figure 21-12.
3. An electric boost pump must be installed for the fuel system. This boost pump should have an operating pressure of 21 psi (for injected engines) or 4-6 psi (for carbureted engines). 1/4" pipe ports (dash 6 aluminum line) are standard for the low pressure boost pumps that Neico stocks. The boost pumps must also be free flow in nature (which means fuel must flow through them without turning them on). These pumps have an inlet and outlet port which can NOT be interchanged, be sure that you are plumbed correctly regarding the direction of flow. Locate the pump on the firewall, just inboard of the gascolator, see figure 21-12.

NOTE: There are a great many high pressure boost pumps found on the used market for fuel injected engines that are NOT suitable for use in the Lancair. Be sure about what you are considering purchasing. (Neico has consequently begun stocking the correct factory new units for our fuel injected engines.) Neico also stocks the 4-6 psi pump.

4. Per figure 12-1, use 3/8" aluminum line to connect the gascolator outlet port to the Boost Pump inlet port. Be sure that the radius is smooth and the line is not kinked.
5. From the outlet side of the boost pump, a flexible line will connect to the engine driven fuel pump. On new pump installations, it may be necessary to adapt the pump threads to the AN type fittings by use of special pump fittings. The Aircraft Spruce catalog lists this part as No. 6470069 (two required). Remember to use only steel AN fittings on the fuel pump since it is attached to a vibrating hunk of iron - the engine.

HIGH PRESSURE "FUEL INJECTION" BOOST PUMP INSTALLATION

Figure 21-12

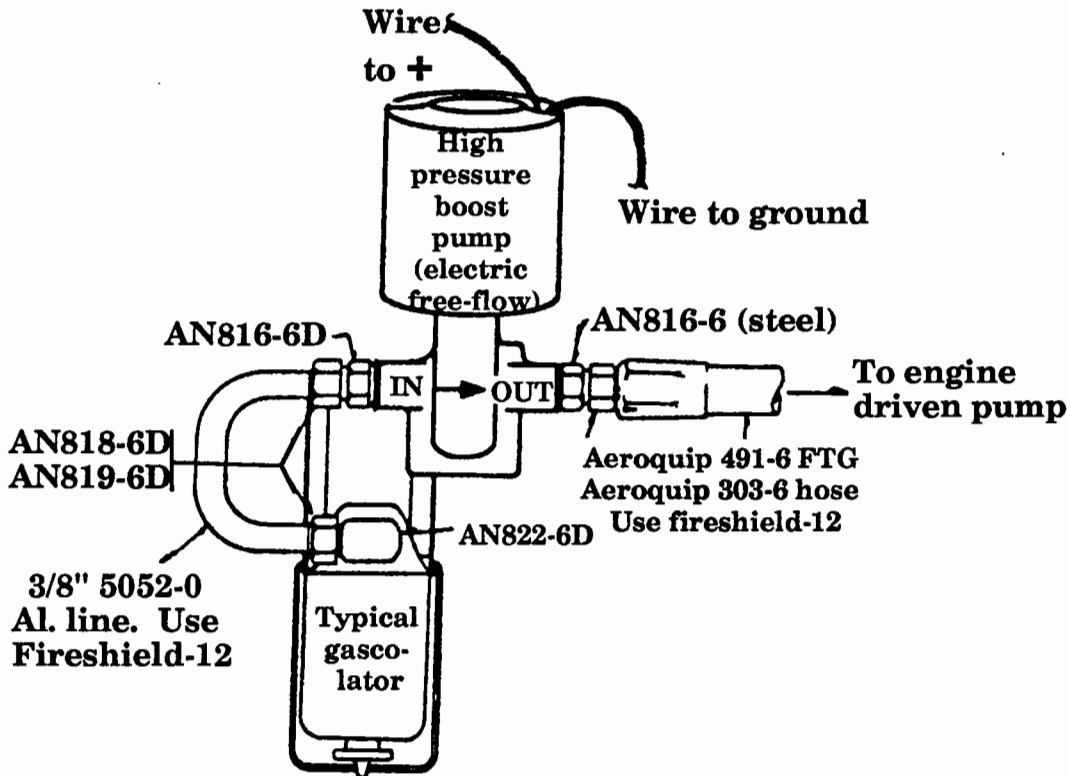

LOW PRESSURE BOOST PUMP INSTALLATION

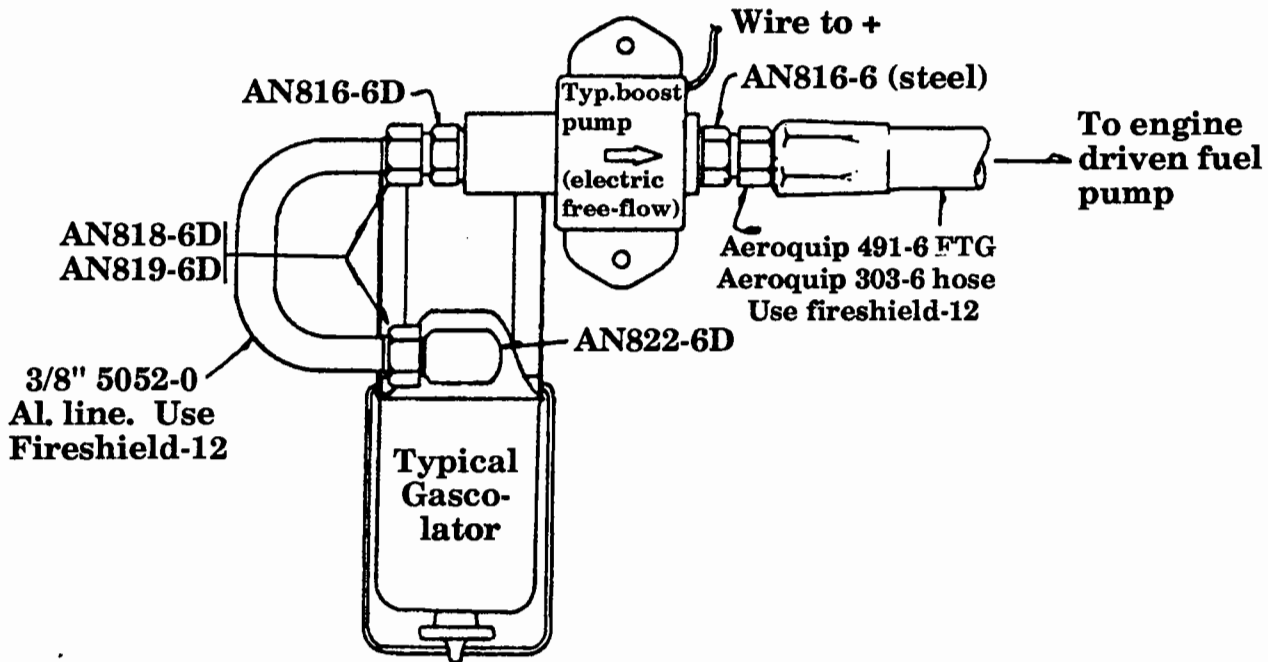

6. Generally, a straight AN816-6 works well on the upstream side of the engine driven fuel pump and a 90° AN822-6 on the down stream side going to the fuel injector or carburetor.

The fuel injector works best with a 45° fitting (AN823-6) to accept the fuel line, carbureted engines use a 90° fitting. The flex fuel line routes aft and up from either the injector or carburetor such as to clear the engine mount and also clear, with as much room as possible, the exhaust pipes. Be sure that there is sufficient clearance from the engine mount so that no binding stresses will be applied to the line. Again, cover these with fire shield.

WARNING: DO NOT use aluminum fittings where flexible fuel line is to be used between fixed position items and the engine (which moves). These aluminum fittings have been known to fatigue and crack with time.

7. Use Aeroquip 303-6 flexible hose with AN491-6 fittings for fuel lines from the boost pump. Use fire sleeve -12 with this hose.

Engine driven fuel pump, plumbing

Figure 21-13

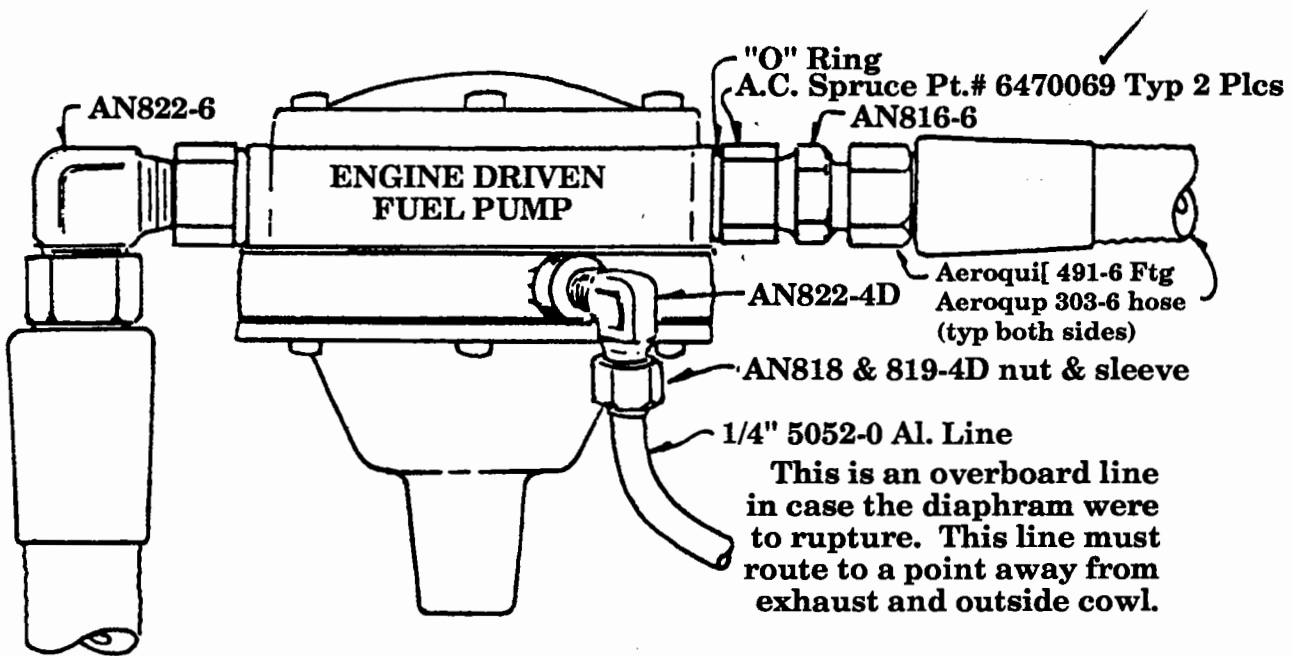

WARNING: The fuel system should be kept as cool as possible to prevent vapor formation and the resultant potential of vapor lock. Particularly true with auto fuels due to their less desirable reed vapor pressure.

8. Adding a fresh air blast tube such that it blasts onto the gascolator and the boost pump is a good idea. A better addition is to build a simple sheet metal shroud around these items to help direct the cool blast air. A 1/4" aluminum blast tube line is sufficient, it can be plumbed from the upper pressure cowl attaching to the rear baffles.

NOTE: It is also recommended that you place some sort of temperature monitor within the engine compartment to check various locations. Temperatures from 100° F to 130° F are common and generally acceptable. Temperatures generally should not exceed 150° F in the rear central accessory area of the cowl. A blast tube to cool the fuel system is still strongly recommended.

9. When the fuel lines are completed, check to make sure that all lines are tight.
10. When you are ready to add fuel, level the plane which will require some blocks under the main gear. This is to approximate a flight attitude.
11. Add one gallon of fuel at a time while in this levelled position and mark the relative position of fuel as it begins to appear on the gauge. Increase the fuel at one gallon increments and note this on your gauge (either sight tube type or mechanical type). Your header tank gauge should provide an indication of fuel amount (i.e., 11 gal.) along with markings for full, half, quarter, and empty. This will provide an accurate measure of fuel in the header tank, but **ONLY** during cruise flight.

WARNING: Remember that during nose up conditions, fuel can appear to be more than is actually present and during nose down conditions, fuel can appear to be less than is present. Fuel levels will indicate accurately only during level flight. This is particularly evident with the sight tube type of gauge.

NOTE: It is important that the engine be run for at least one hour on the ground prior to any flight attempts. After this ground run, it is also recommended that the fuel line be disconnected on the up stream side of the engine driven fuel pump and a gravity flow check be made. This will provide an indicator of any blockages that may exist in the system from dirt and contamination accumulated during the building phase. You should have no difficulty flowing 15 gph with a nearly full header tank in a level condition, if you cannot, then look for a partial blockage somewhere.



F. Mounting the engine

The engine can be hung on the motor mount using an automotive engine hoist (you can rent these). Bolt up the engine with the rubbers and hardware that is appropriate to your mount style (Dynafoal or Conical). For engines with conical mounts, Lycoming lists a crush dimension as a means of setting the proper load on the mount pads.

For mounts with solid inserts (Continental 0-200 and Lycoming dynafocal) the bolt torque can be used. The following is a chart of approved bolt torques as listed by Continental:

BOLT THREAD SIZE	TORQUE (inch/pounds)
8-32 - - -	22-30
10-32 - - -	36-50
1/4-20 - - -	75-85
1/4-28 - - -	90-110
5/16-18 - - -	155-175
5/16-24 - - -	180-220
3/8-16 - - -	220-260
3/8-24 - - -	220-260
7/16-20 - - -	400-450
1/2-20 - - -	550-600

Engine incidence:

1. When mounting the engine, it is most important to check the crankshaft level condition of the engine on the airframe. To check this, level the airframe and check the level condition of the engine. This can be accomplished roughly by laying a level across the top of the valve covers but more accuracy is achieved by setting a level against the vertical flange of the crankshaft (where the prop will later attach). A small protractor type level works well here.
2. If necessary, shim the engine to achieve a level attitude. This can be accomplished using AN970-7 washers under the engine mount pads (between it and the firewall). Essentially, what ever thickness is placed under the bottom two must be reduced by a factor of 1/2 and placed under the middle two attach points. (I.e., if two are used under the bottom two pads, use one under the mid pads.)

Also, you can shim between the engine and the dynafocal mounting pads by inserting the same AN-970-7 washers. This location will have a little greater effect than the same thickness washers placed under the mount/firewall location.

This engine attitude, while not critical to safe and effective flight operations, is desirable since a nose down engine will result in less prop clearance and an increase in drag. We have flown with incidences of from +1° to -1° and the differences are nearly undetectable in flight operations however prop ground clearance is noticeably affected.



Engine offset

3. The standard offset is 1-1/2°'s to the right. Here again, it does not appear to be critical and certainly less important than the incidence in a practical manner. We have never bothered to make any adjustments, we know of no one who ever has, so if you're close to square with the firewall in the first place, consider it done.

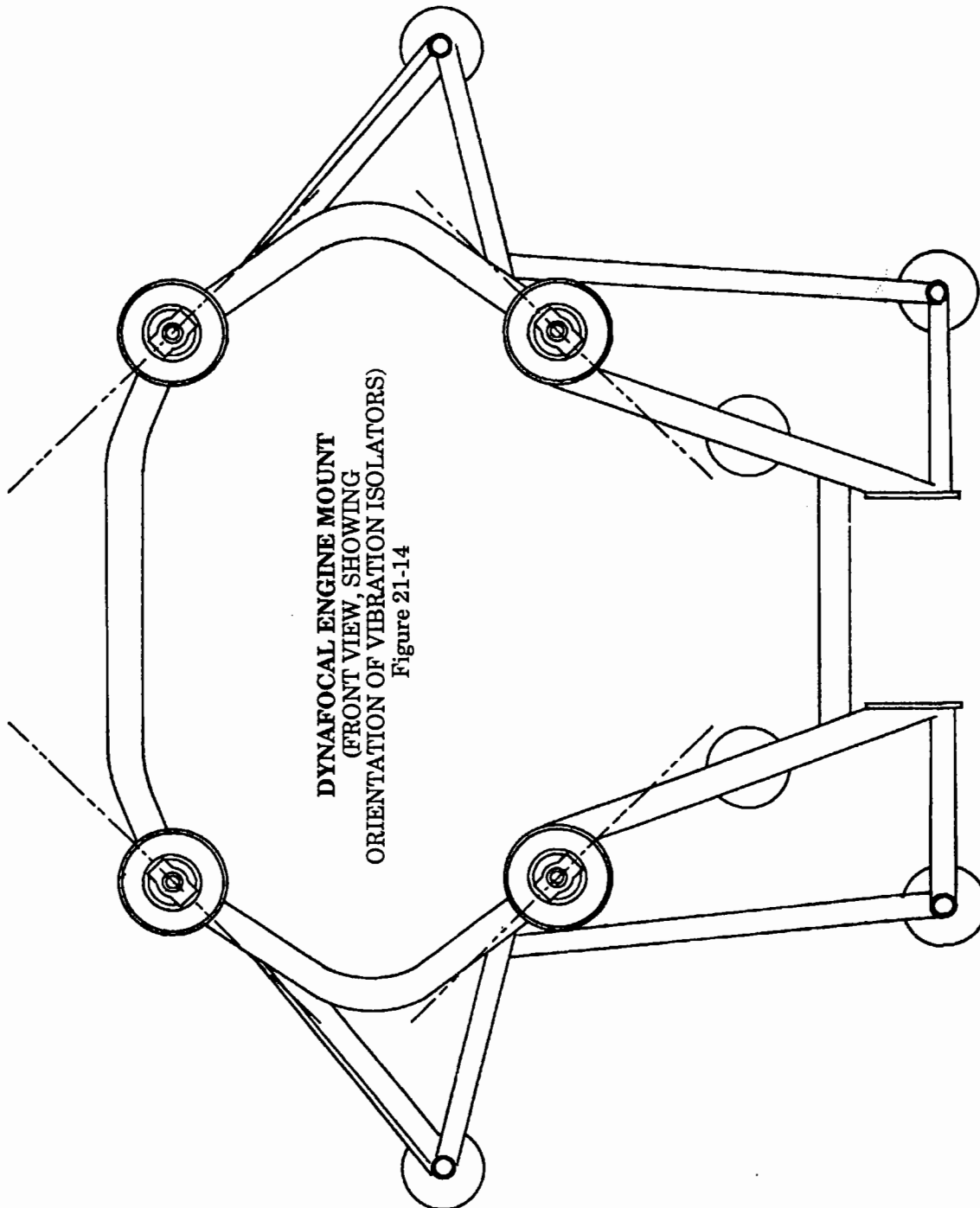

NOTE: To select the proper Lancair engine vibration isolators:

- 235 engines, fixed pitch prop, use 94150-40
- 290 engines, fixed pitch prop, use 94150-01
- 320 engines, fixed pitch prop, use 94150-01
- 320 engines, constant speed prop, use 94150-41

Engine mounting biscuits

Figure 12-15

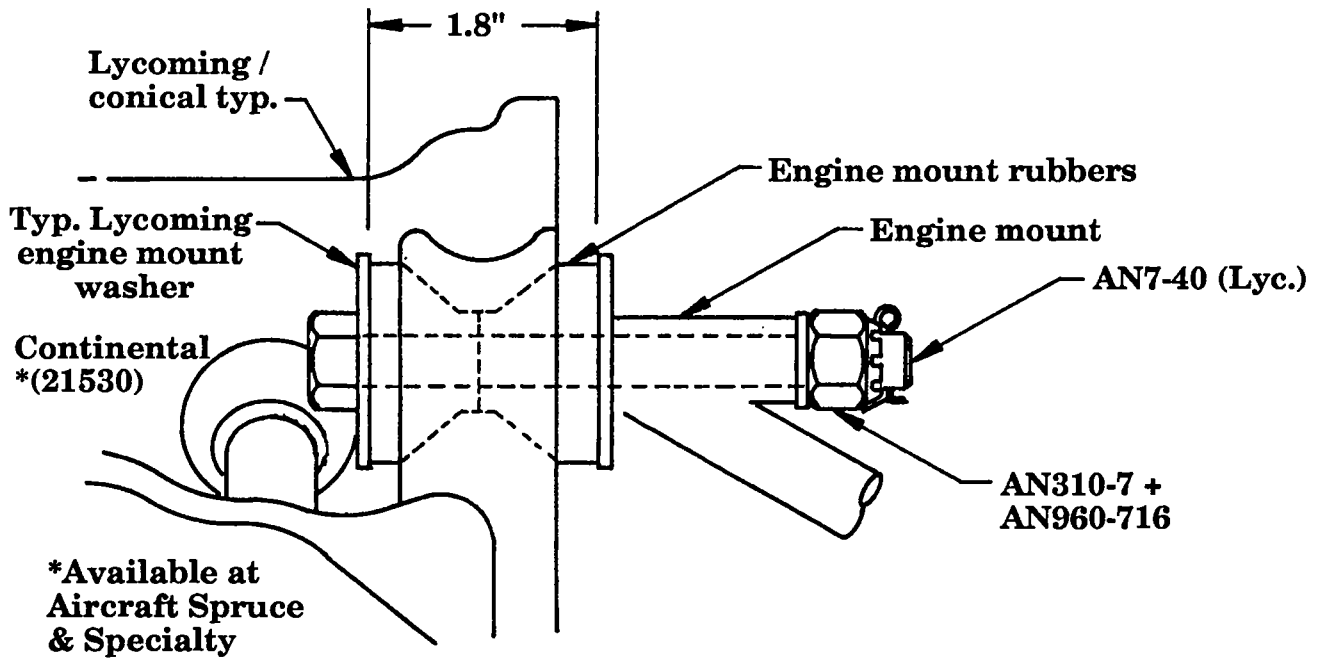

Dynafoal Mount

For attach bolt use AN7-34

94150-40
4 places

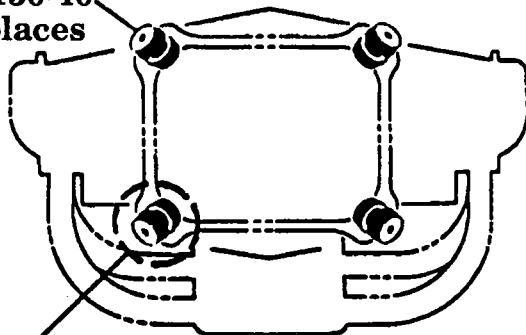

See exploded view for parts breakdown

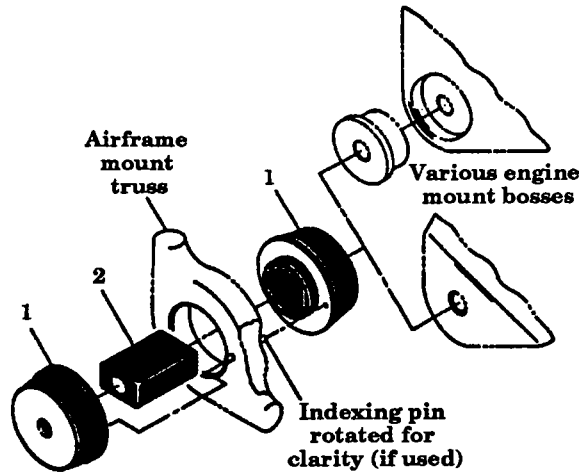

G. Cowling installation

This installation will benefit from the help of one or two other people to hold the cowling in place at each side and at the spinner; nothing heavy, just a steady hand. It can be done using clamps/tape/clecoes/etc., but it will be very frustrating and time consuming, at best. Before you start, the engine must be mounted with the proper pads, bolts, torque setting, etc. Plus you'll need to have the 4" prop extension attached (for the fixed pitch prop installation) or have the constant speed prop temporarily positioned and have the spinner backup plate attached. All of this is necessary to properly align the front of the cowling to the spinner.

The lower cowl scoop will have to be removed and modified if you're installing a fuel injection system (either fwd mounted injector or updraft injector) or a carbureted 180 h.p. Lycoming, the modified scoops are available from Neico as an option. It is best to install the cowl to the fuselage first to easily hold the cowl shape then remove the existing scoop and attach the replacement scoop.

NOTE: The engine will sag under the effects of heat and pressure on the rubber mount pads. Usually a vertical drop of 1/8" to 1/4" as measured at the spinner backup plate, is common. The cowl should therefore be fit to a position, about 1/8" - 1/4" lower, to allow for this sag. It is always difficult to hit this "sag variable" right on the money so if you are particular about the spinner to cowl alignment, plan on making some adjustments after the first twenty hours of flight. This can be done in a manner similar to that described for shimming and setting the incidence of the engine.

Cowling pre-fitting trim requirements

Figure 21-16

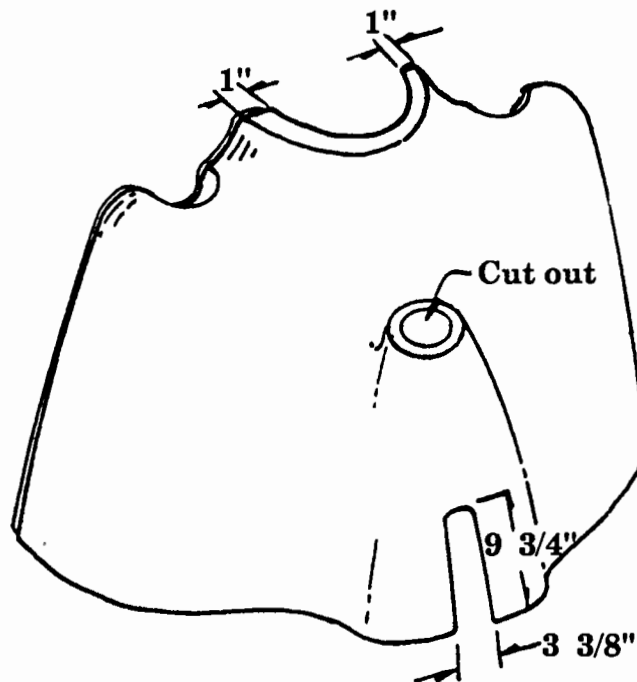

D. Silicone sealing

1. Finally, for a good seal that produces maximum cooling and minimum drag, use some high temperature silicone around all areas that must seal against the engine. This is primarily around the front engine case areas. Simply place a nice smooth bead between aluminum plates and the engine case. Another area of particular benefit is around the rear engine accessory case.
2. Also note that the front left panel (I) is an excellent location for a sponge type remote air filter for the carb or injector. A fiberglass box can be fashioned and attached to the bottom such that it holds the filter directly under the panel, a large hole is then cut into this panel for the largest possible filter installation (see figure 21-33).



E. Oil cooler air line

1. Your engine will require a 7 to 9 vane oil cooler, in other words, it needs a pretty good sized cooler. The best high pressure air source for the cooler is from the right rear baffle panel (figure 21-21, panel E). Attach a 3" flange to accept a length of 3" Scat tubing which will be run to the oil cooler plenum. A flange can be pop riveted to the (E) baffle panel and extend aft. The oil cooler installation will be discussed in more detail later but in general, it can be located on the left lower side of the firewall (see figure 21-1). The 3" Scat tubing will cross over the top rear of the firewall and down to the cooler where it should enter into a fiberglass plenum attached to the top of the cooler. 1/2" oil lines should be used from the engine to the cooler. See figure 21-26 for a typical oil cooler installation onto the firewall.
2. Refer to figure 21-26 for a simple method of making a Scat tube attachment. It is shown for a typical piece of 3" Scat tube but the principle will work well for any size as long as it doesn't get too small. Attach the Scat tube with some high temperature silicone and very light clamping pressure from a hose clamp that is placed close to the face of the sheet metal surface.



TYPICAL OIL COOLER INSTALLATION

Figure 21-26

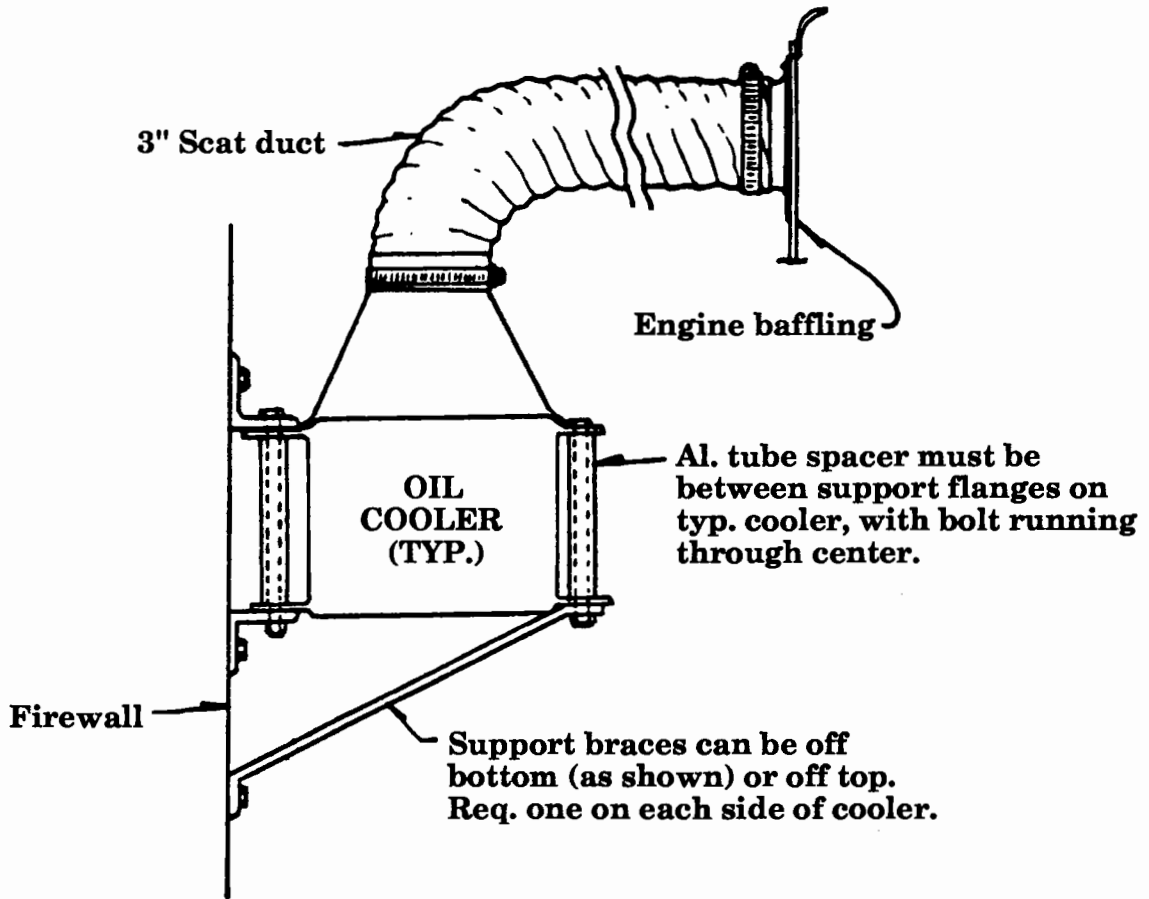

Forming scot tube attachment

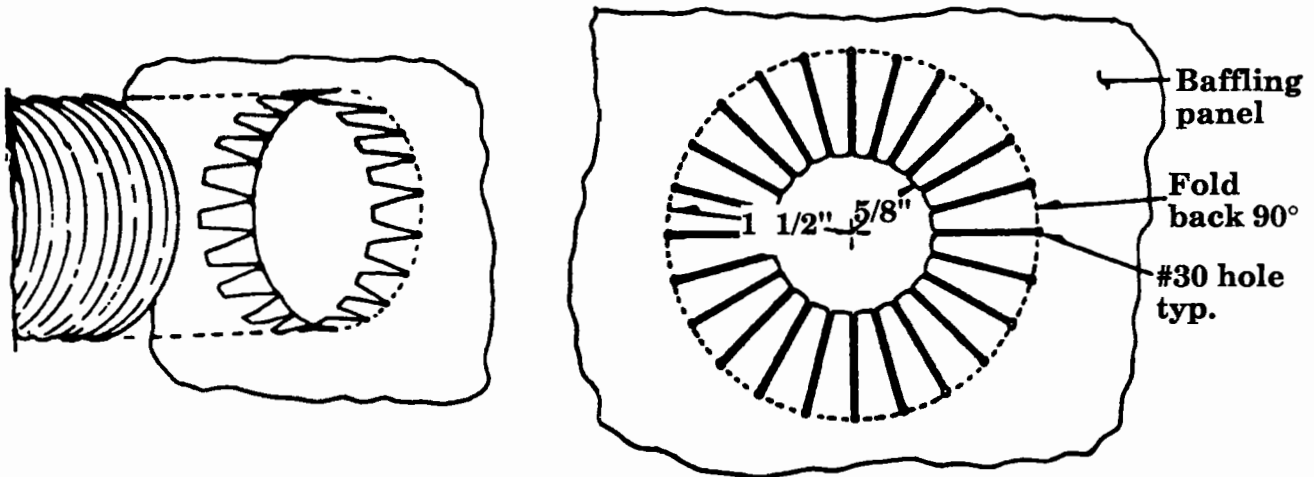

BAFFLING FLEX SEAL
Figure 21-27

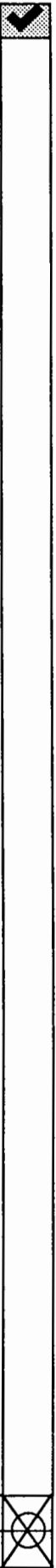
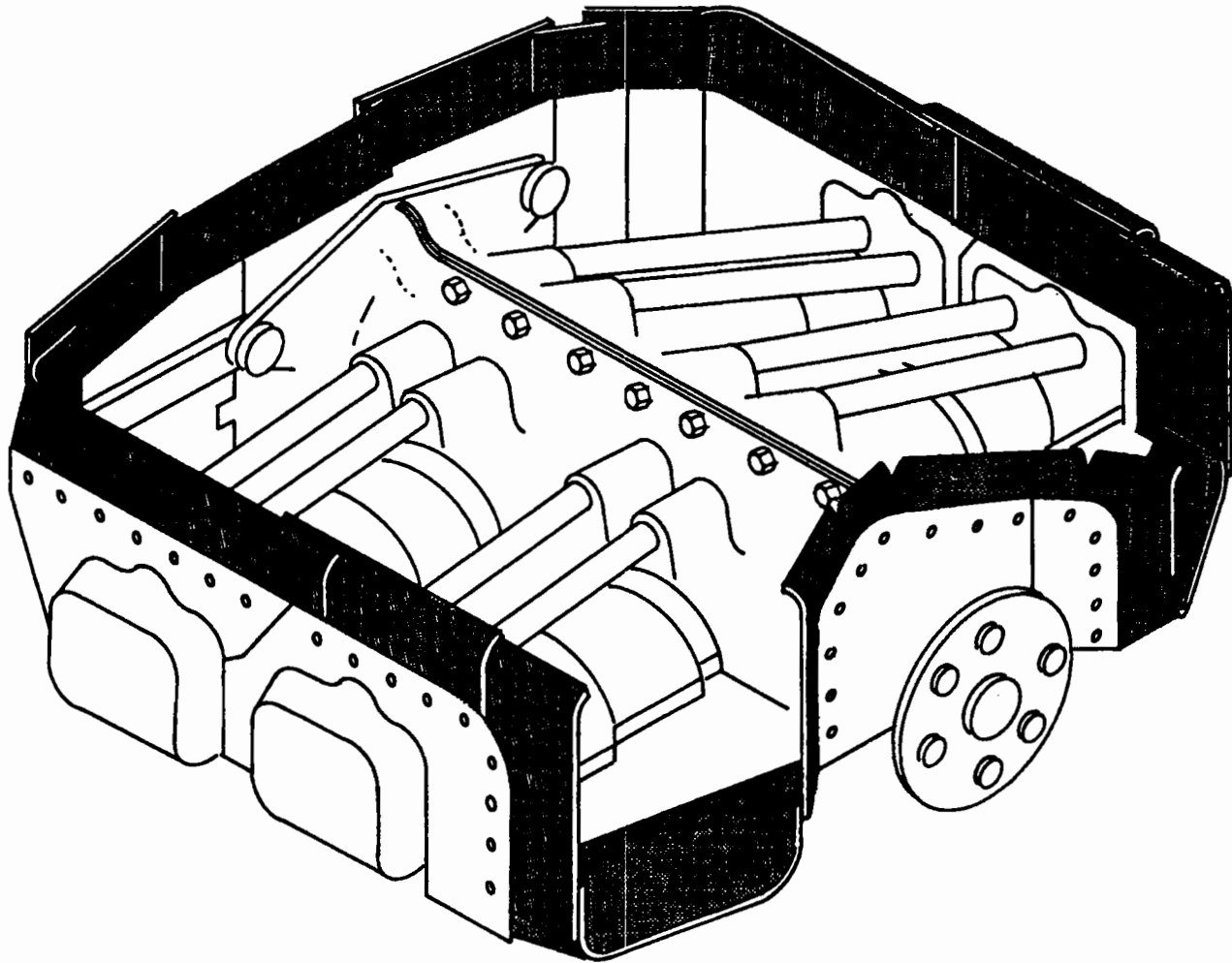

F. Magnetos

Wiring up a pair of mags is very simple, about as simple as the 1930's era mag that it is! Essentially, the mag is "hot" all the time and must therefore be grounded out to kill the spark. The mag switch merely grounds out the mag in the off position. Mag wires should always be run with shielded cable so that the contacts do not interfere with radio and Loran C signals. A #20 wire gauge is sufficient.

Magneto filters are also a good idea since they will further filter noise from the system. They are available from most repair stations and catalog houses. You can use individual on/off switches for the mags or a keyed type rotary switch (Bendix type).

The upper plug leads location is not critical and should thus be located after oil cooler locations and blast air line locations have been calculated.

NOTE: It is often considered advisable to have a separate starter switch (i.e., a separate starter button instead of the Bendix type mag switch with the starter position on it). The reason for this is inertia. If you have the means of first getting the engine spun up before switching on the mags, your inertia is increased and a kick back is avoided. If the engine were to kick back while the starter is engaged, it could break the starter gears or starter housing.



21-48

Chapter 21

REV. 0 / 11-1-91

ENGINE INSTALLATION - LYCOMING



G. Remote oil cooler mounting

The Lycoming 320 and 360 MUST have an oil cooler to keep temperatures within the recommended operating limits. Due to the tightness of this engine installation, there is a recommended location for the 9 vane oil cooler, mounted to the firewall as shown in fig. 21-1. (However, with careful planning and layout, other locations may be possible.)

1. First a shroud must be made out of 3 BID fiberglass (or aluminum) per figure 21-28. This shroud must make a transition from the 4" x 7" rectangular oil cooler to the 3" round flange for the Scat duct. The Scat duct must pick up air from either: a NACA duct formed in the side of the lower cowl, or from the aft wall of the baffling (piece E).

NOTE: If the pressure cowl location is chosen, one must make sure that the nearest cylinder is not robbed of its needed cooling high pressure air. During the first flights, monitor temperatures within the engine compartment, and note the temperature of the rear cylinders, especially the one over which the oil cooler air is being drawn. If it is running hot, it may not be getting the proper air flow due to the flow to the oil cooler, in which case step 2, below, is recommended to assure proper high pressure air to rear cylinder which is nearest the oil cooler air inlet.

2. Add a curved flange, see figure 21-29, behind the cylinder fins and extending upward and fwd thus helping to trap pressure air and route it down through the fins of the back cylinder.
3. Use a standard 3" flange and attach it to the back baffling piece (E). This places the air inlet on the left side of the plane, and the air pick up flange (on the oil cooler) on the right side, subsequently the Scat hose must be about 36" long to route between the two.
4. Mount the oil cooler to the firewall in the location shown in figure 12-1. It must be very securely mounted to prevent the possibility of cracking from vibration. The standard Harrison type of coolers have two sides that attach, both sides must be supported. Do not simply hang the cooler from only one flanged side, it would fail, see figure 21-26.
5. Clamp the 3" Scat duct to the baffle flange and to the shroud flange with screw type hose clamps.

SHROUD, OIL COOLER

Figure 21-28

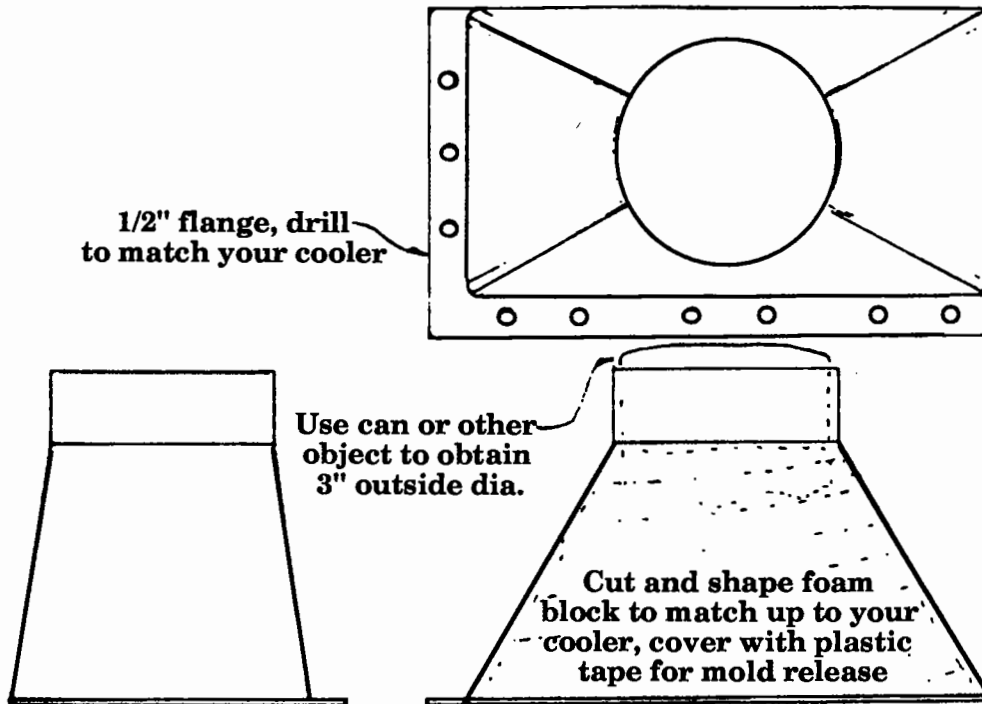

BAFFLING, FLANGE - REMOTE OIL COOLER

Figure 21-29

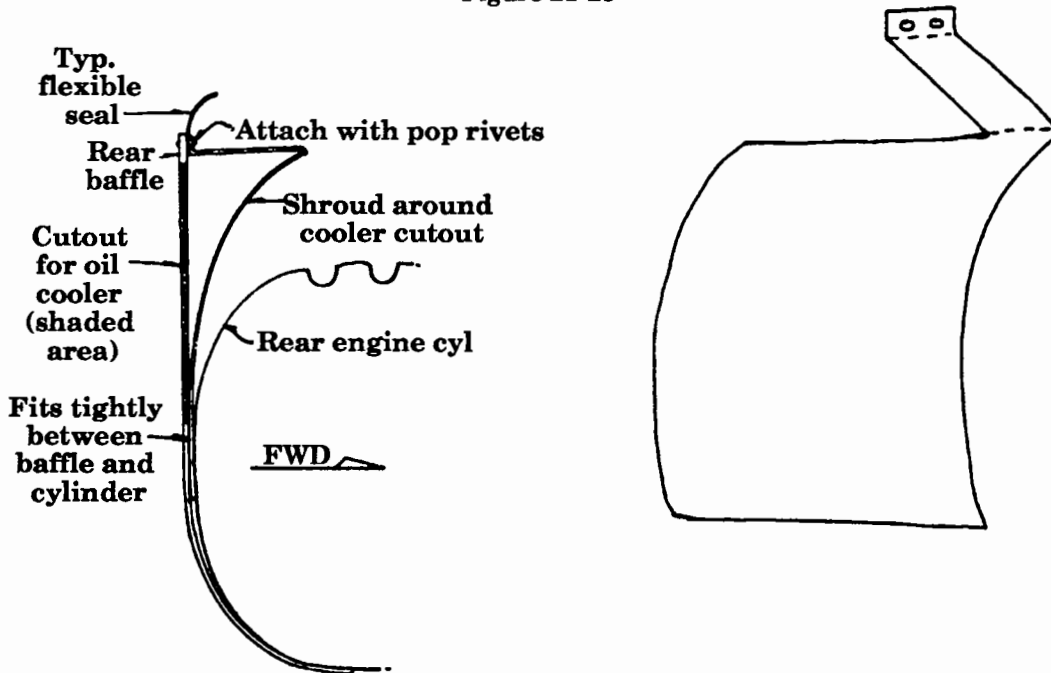

H. Spark plug leads

The upper plug leads should be routed through nylon two piece housings (supplied with the baffle kits) which attach to the rear baffling pieces (E & F). Their location is not critical and should thus be located after oil cooler location and blast air line locations have been calculated.

1. Mark the location where the lead wires will pass through the rear baffle plate. Punch two 3/4" holes, 5/8" off center from each other and file out the middles, thus producing an oval that is approx. 3/4" x 1-3/8" to accept the two piece housing for the upper plug leads, see figure 21-25. Attach the housings with two AN526-132 machine screw and AN365-1032 nuts.

NOTE: The AN365-1032 nuts are rated for up to 250° F environments. Our engine compartments have consistently proven to run from 130° F to 150° F. If your engine compartment gets any hotter, the all metal nuts should be substituted. Thus, it is highly recommended that a temperature probe be run in the rear center engine compartment to monitor temperatures early in the test flight program.

2. Be very careful to protect the leads against any possible friction points around baffling pieces, etc. Leads can be tied with nylon zip ties, the best method of using these ties is the double tie method, and is shown in figure 21-25. With this double tie approach, the cable or wire is securely anchored just OFF the fixed location with nylon between it and that hard spot.
3. The lower plug leads obviously do not run through the baffling but care must be taken to assure that they will not be subjected to chafing or direct contact with exhaust pipes. Secure the lower plug leads with the same method as used above.



I. Exhaust system

The Lycoming exhaust systems that we manufacture are stainless steel full crossover systems. There are several different models of exhaust, depending on the type of engine used. Please consult with our technical staff when selecting your exhaust system.



21-52

Chapter 21 REV. 0 / 11-1-91
ENGINE INSTALLATION - LYCOMING



J. Cabin heat system

Obviously cabin heat is not a necessity (higher latitudes excluded) but it is generally installed even for us Southern California residents. A minimum of heat is required in a well sealed cockpit, our standard heat valve is 1 1/2" dia. and more than sufficient (see figure 21-30). **THE CABIN HEAT MUST BE FED WITH FRESH AIR ONLY.**



CABIN HEAT VALVE

(Half scale shown)

Figure 21-30

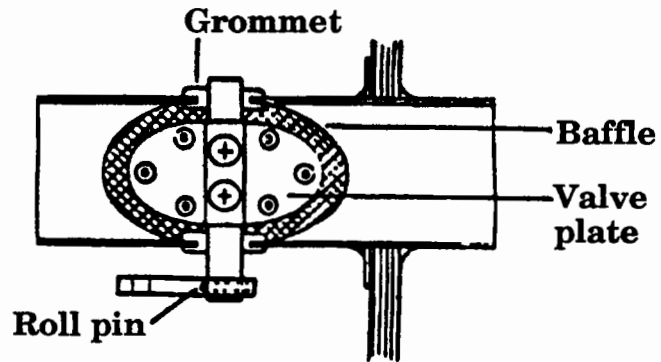
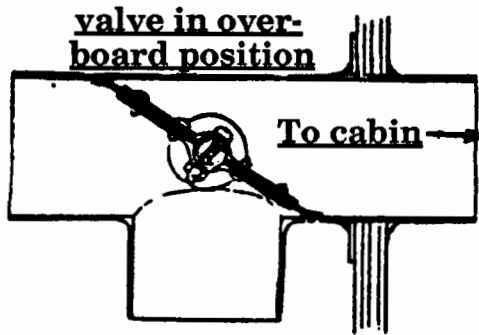
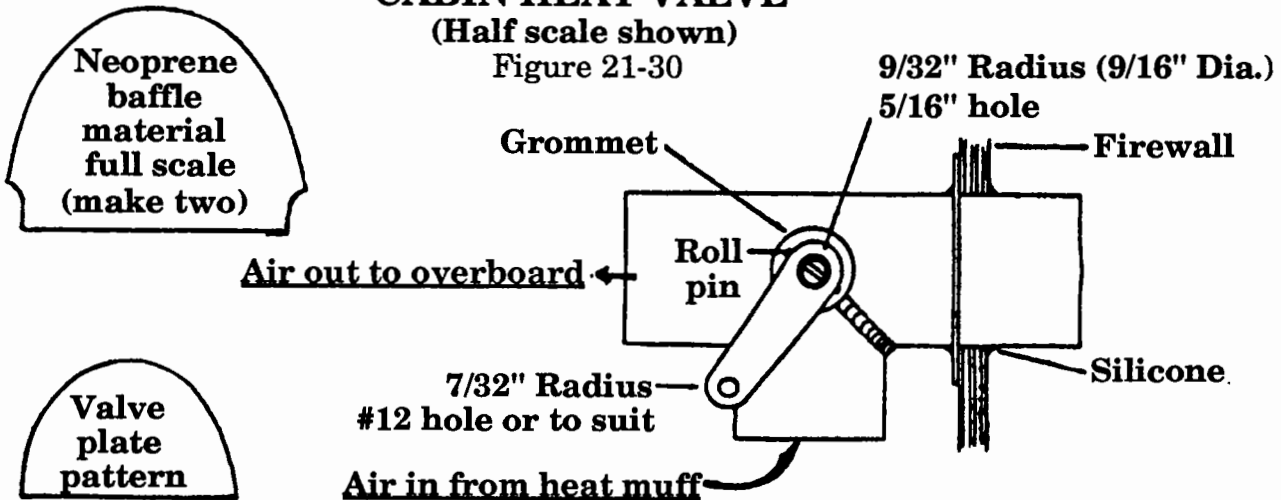

1. Heat muff locations will vary with the style of exhaust required. Position the air duct flanges on the hat muff shell so that they are in the best possible position to run a duct fwd to a fresh air inlet flange and to run a duct aft to the firewall cabin heat valve (this may need readjusting when the ducting is routed, so keep the clamp screw on the heat muff in an accessible spot).



2. From one of the hose coupling flanges, on the heat muff, connect a piece of Scat ducting of 1 1/2" dia. This will typically be routed fwd to baffling piece "K" (this, long way around, routing is to leave room for the air filter installation on baffling piece "I"), install a duct flange here to pick up the fresh air.
3. Connect a piece of Scat ducting of 1 1/2" dia. to the remaining heat muff flange. This will be routed aft to the cabin heat valve located on the firewall per figure 21-1 (if the cabin heat valve was not already installed, install it now per figure 21-30).
4. The Scat duct from the heat muff must attach to the valve per figure 21-30.

WARNING: Incorrect installation of the cabin heat system could allow toxic fumes into the cabin. THIS COULD BE FATAL!

5. The heat muff is always producing heat if the engine is running, even if the valve is closed. The overboard side of the valve should have Scat duct attached to it and extending down and pointing aft near the cowl air exit. This way the hot air will not be dumped directly into the engine compartment.



K. Air intake system (engine)

1. Ram air is always the most effective induction system, but engine life is prolonged if a filter system is used when operating on the ground. The easy system is one of simply installing a coarse sponge filter to keep out the big particles. This is a very common installation whereby the air box is simply fitted with a coarse sponge type of filter.

WARNING: Be sure the filter does not overly restrict air entering the engine which could rob the engine of power. See figure 21-31.

2. To build a suitable air box, start with a block of foam and carve it to fit against the carburetor and extend forward to the inlet on the lower cowling (be sure you have the starter motor installed, to allow room for it!). A flat area should be maintained on the upper forward area where you can place an air duct flap for carb heat. Across this area, the corners should be relatively square and tightly radiused thus more suitable to a tight seal of the flap that will divert carb heat. A second flap can be installed to serve as a means for ducting remote filtered air. (This allows for a larger air filter to be placed on the forward left baffling plate which is ducted down to the carb air box, see figure 21-33 and figure 21-35.

When the shape is correct, cover the "plug" with plastic tape as a release. Then lay 4 BID over the upper half of the plug and allow to cure but during the "green" stage, when the BID is about 3/4 cured, knife trim to a point that is just below the middle of the sides. Discard the trimmed off BID. Allow the piece to fully cure.

3. You will next lay up 4 BID over the lower portion of the plug but first cover the lower 2" or so of the upper BID with plastic release tape. Then lay up the 4 BID onto the lower portion and extend over the cured 4 BID upper portion by about 1". Trim this in the green stage as well. Allow to cure fully.
4. Pry the lower half off the plug then pry the upper half off the plug. You now have two custom mated pieces that form a full airbox (see figure 21-31).
5. Fit the carburetor to the upper portion of the air box and attach that piece to the carburetor using the four holes in the carburetor base. These screws should be safety wired together.
6. The air box should fit into the fwd air duct on the cowl but don't fit it in too tight or else you will have a hard time removing the lower cowl. A micro fill of that forward 3/4" portion of the lower cowl air scoop will generally help the installation and removal of the cowl since there will be less of a tendency for the cowl to "back lock" onto the air box.



7. A **very coarse** sponge type filter (we've found a Cessna 150 filter, cut to fit, then split to half-thickness, to work well) can be installed directly onto the front of the air box. Be careful to secure a coarse wire mesh behind the filter with at least 4 BID to prevent the filter from getting sucked into the carburetor thus a wire mesh made of 0.050" wire with not more than 3/8" to 1/2" spacing is required aft of the filter (between it and the carburetor).
8. A more elaborate filtering method is also possible. Make a cover housing for a larger sponge type of filter on the front left baffling panel (see figure 21-33). Then route down with a 2 1/2" Scat duct to the flapper valve on the carb air box. This will thus allow full ram air when operating at altitude and filtered air when operating low and on the ground. This is obviously more work but it provides the best of both worlds (see figure 21-34). (Note: The airbox shown in figure 21-31 is available from Neico, and includes most of the parts and hardware shown).
9. One word of caution, if you are intending not to run any filter at all (many aircraft don't) you should then at least install a medium coarse screen across the front of the air box to prevent large foreign matter from entering the carburetor and possibly plugging it to the point of engine air starvation. This screen should also be well attached with typically 3-4 BID.
10. There are 3 different air intake configurations currently for the Lancair 320, depending on the type of engine, and its induction system, you have selected for your particular aircraft.
 The standard 320 lower shroud (see figure 21-32 A) is designed for use with Lycoming 320 engines using a bottom mounted carburetor. If you are using an L320 with bottom mounted fuel injection, or an L360 with either bottom mounted carburetor or fuel injection, then you would use the shroud shown in figure 21-32 B, which has a deep 'belly' to accommodate our pre-formed air box (figure 21-31). For engines equipped with front mounted fuel injection, use the shroud shown in figure 21-32C.



AIR BOX CONSTRUCTION

Figure 21-31

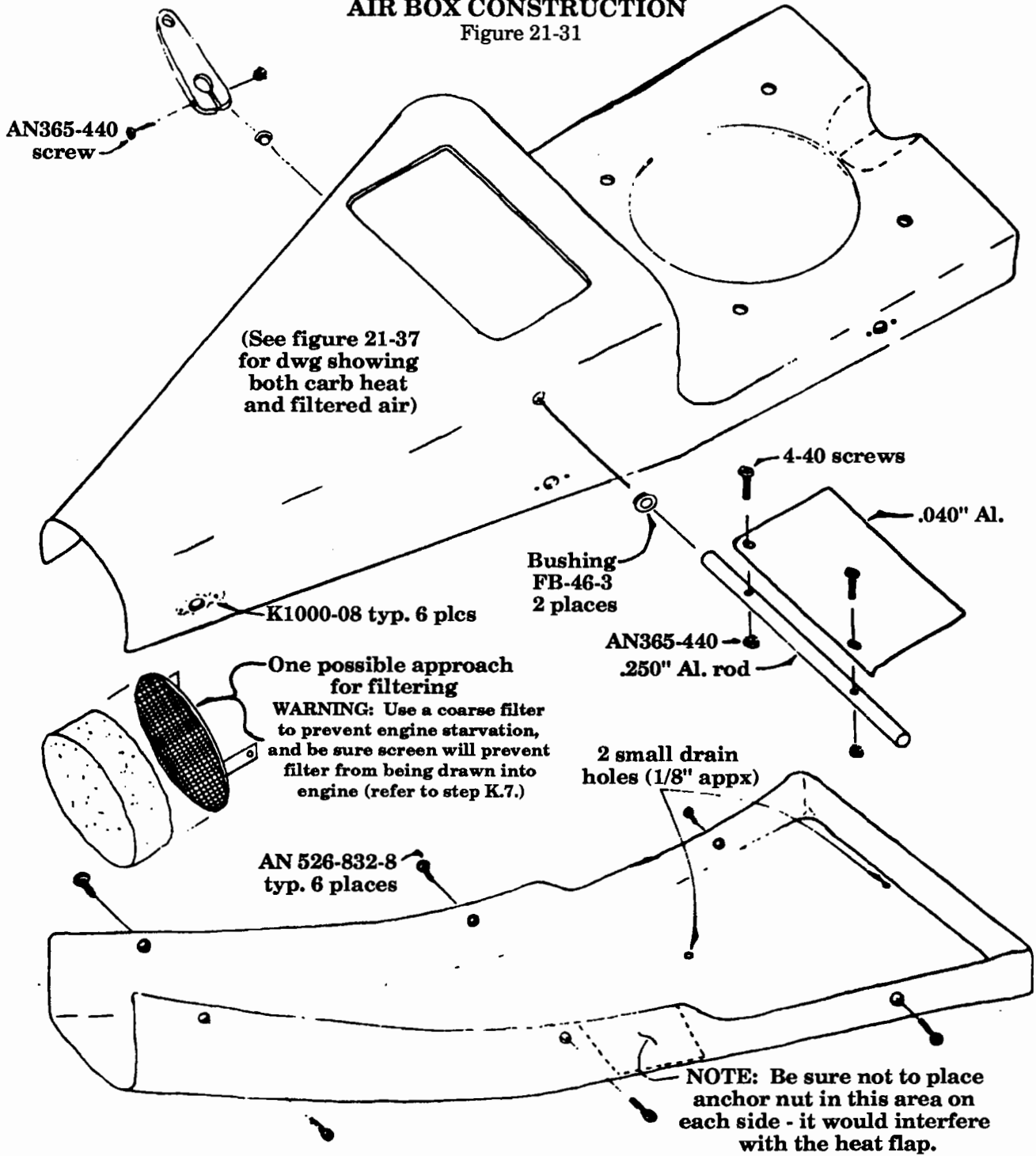

L320 Shroud configurations

Figure 21-32

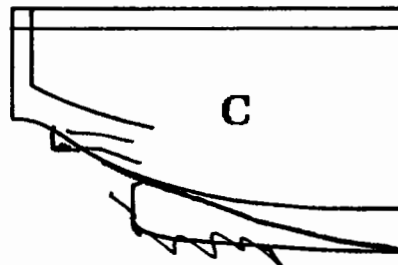
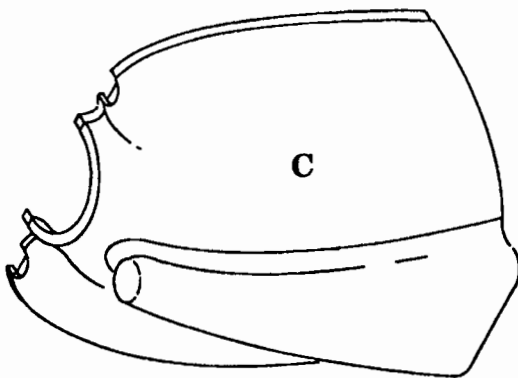
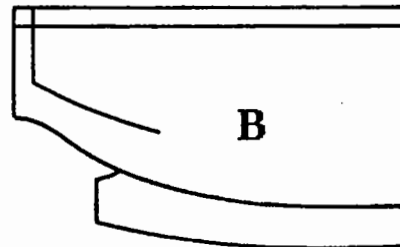
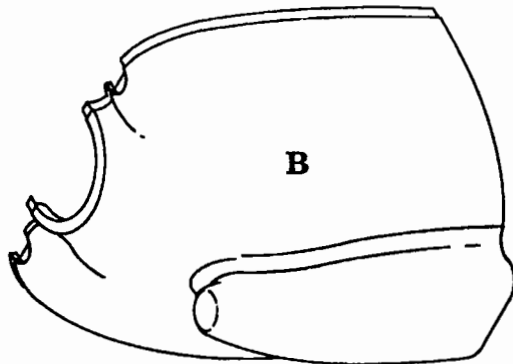
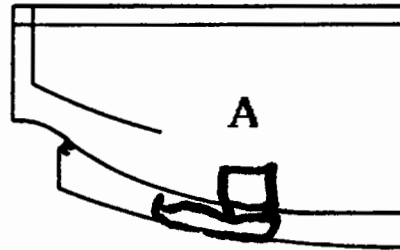
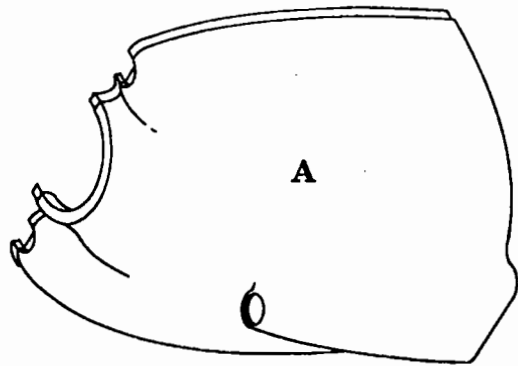

Remote filter air box assembly

Figure 21-33

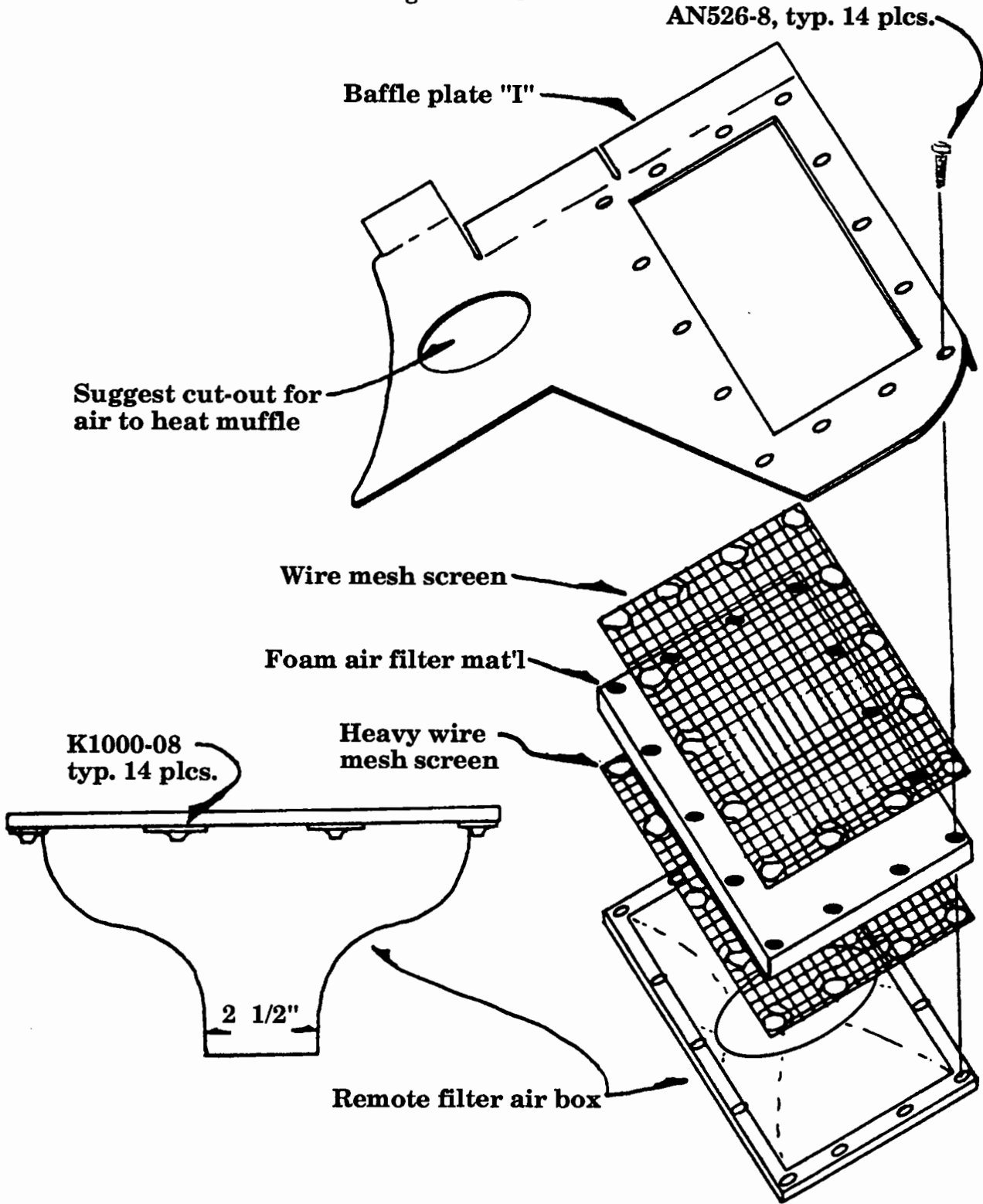

Typical ram / filtered air installation for front-mounted fuel injection

Figure 21-34

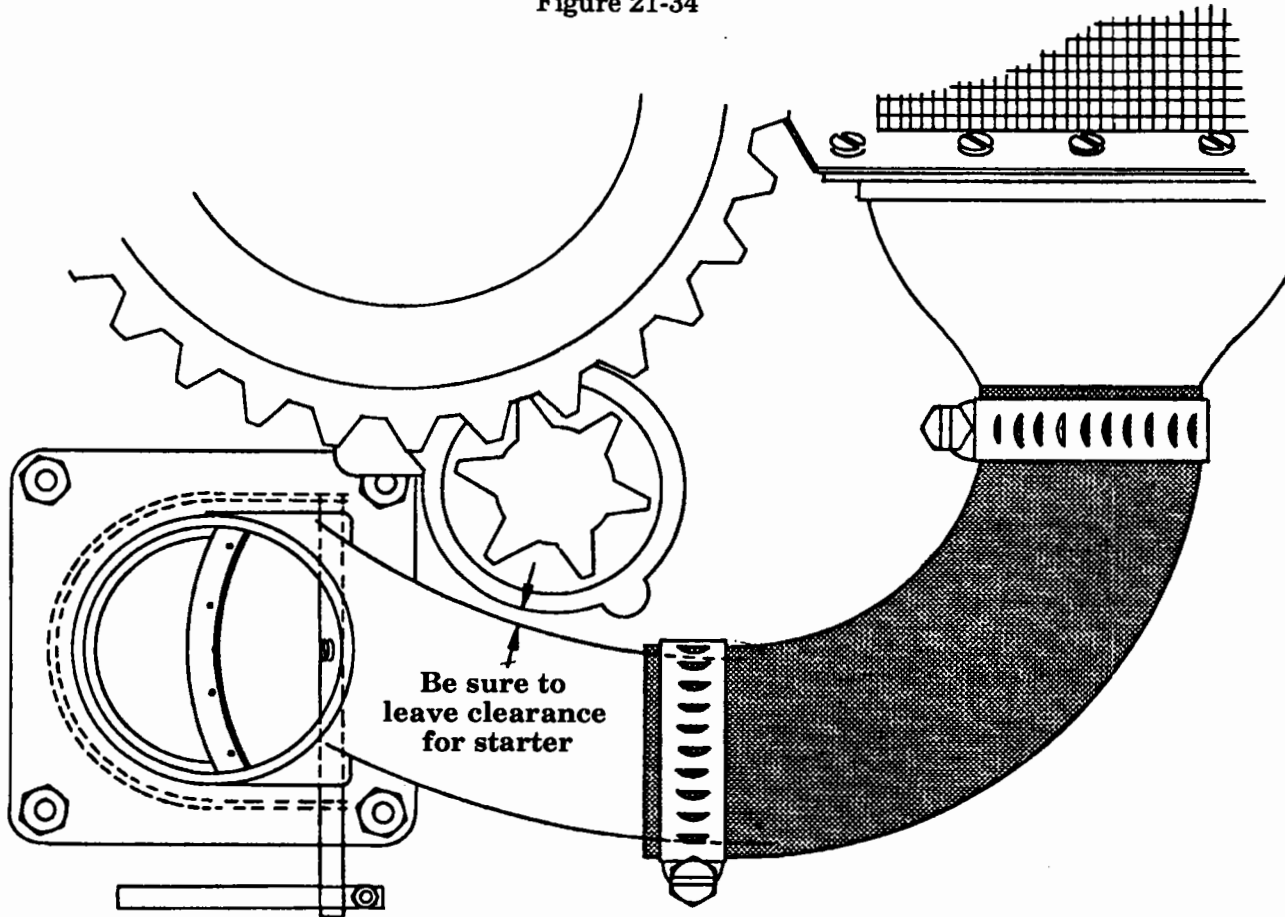

Selector valve shown in mid-position between ram and filtered air

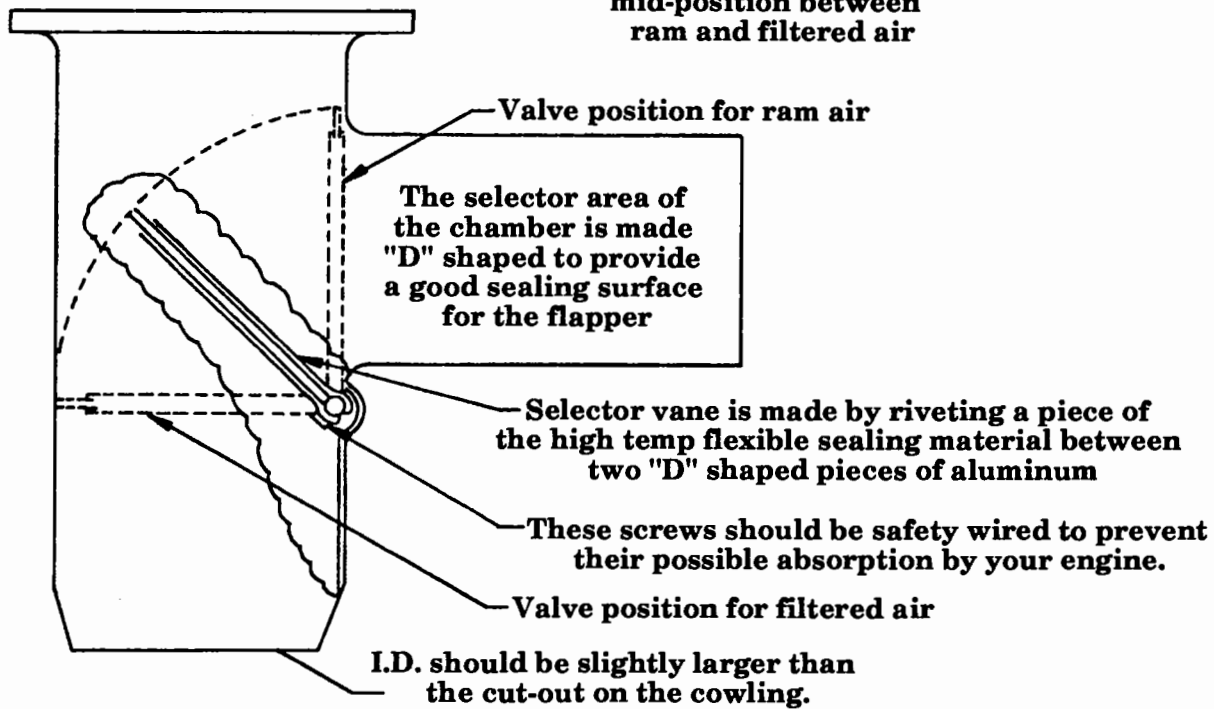

Ram airbox, with both carb heat and filtered air

Figure 21-35

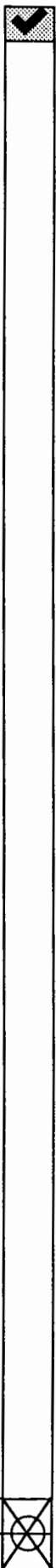
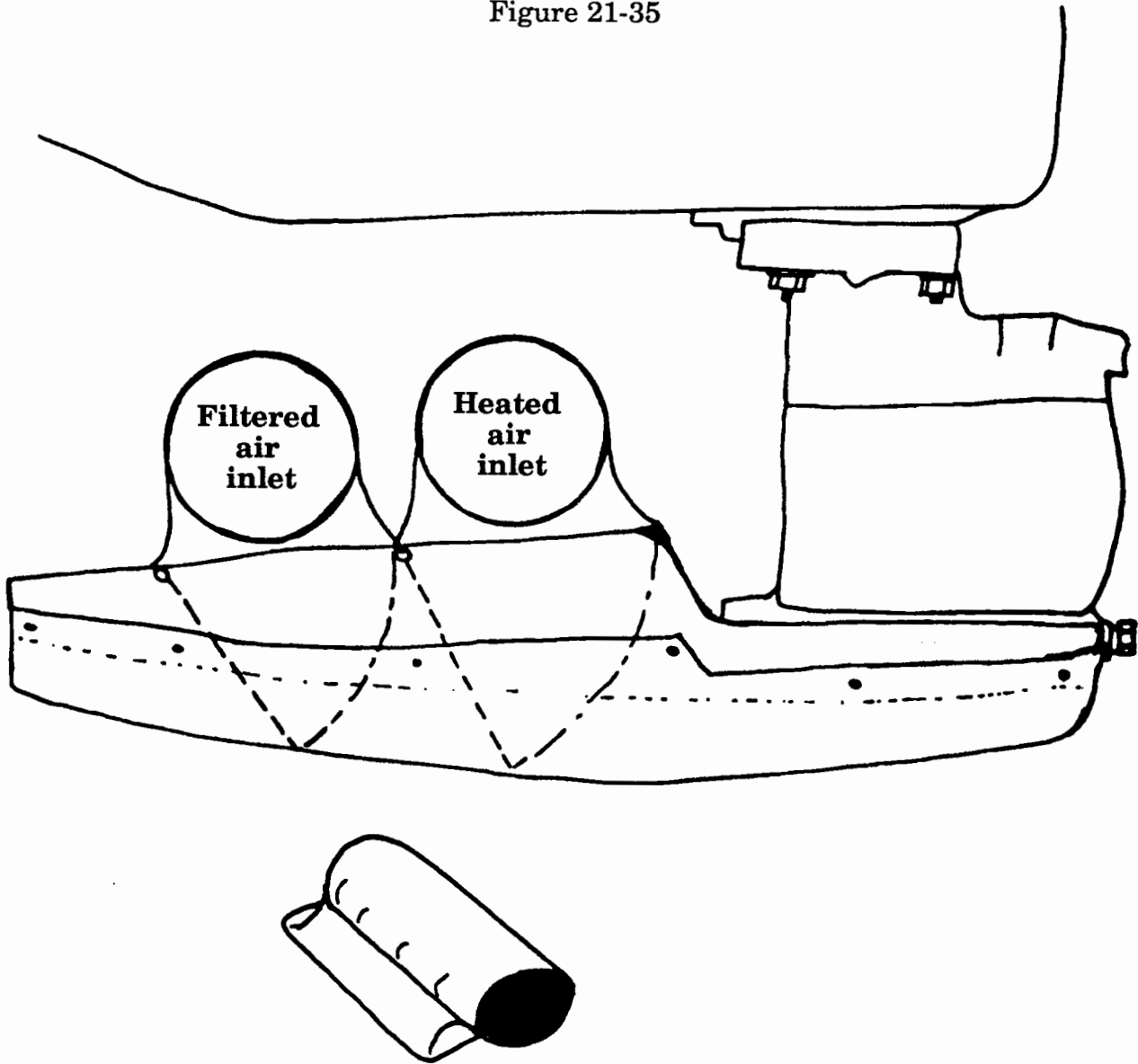

Propeller installation

Lancair 320's are designed for use with a constant speed prop, but fixed-pitch wood can be used (but you will have to get weight forward, i.e., battery next to firewall, etc.). If you are using a constant speed prop, use steps L1-7, then proceed to section N., spinner. If your choice is a fixed-pitch wood prop, proceed to installation steps M1 thru M9, then on to section N., spinner.

The most common choices are the constant speed models from Hartzell, (2 blade), and the MT 2 or 3 blade (the Hartzell 3 blade is too heavy). If you order the MT prop, get their back plate & spinner (we have spinners & backup plates for the Hartzell 2 blade).

L. Propeller installation, CONSTANT SPEED

1. Be sure that the mounting surfaces of the engine and prop flanges and the spinner backup plate are clean, as dirt will throw the prop out of alignment. Slip the spinner backup plate over the prop flange.
2. Place the starter ring assembly onto the motor flange, with the oversized stud in the oversized hole to properly orient your timing mark.
3. Prepare the prop 'bolts' by sliding the six studs through the extension flange from the rear, and thread the castle nuts onto them until the hole in the stud lines up with the slot in the castle nut, and then drive in the stainless steel pins.
4. Slip the spinner backup plate over the prop flange and, being careful not to damage the internal "O" -ring, slide the prop onto the motor flange. Once the prop is started on, it can then be snugged up by carefully tightening the bolts on a cross-rotation manner such that the prop is always kept 'square' to the flange. **DO NOT ALLOW THE PROP TO GET OUT OF SQUARE, THE DRIVE LUG HOLES IN THE PROP WOULD BECOME DAMAGED.**
5. With the prop snugged up, the proper torque must be established on the prop bolts.

THIS PROP TORQUE SETTING IS CRITICAL TO SAFE OPERATIONS.

You'll have to check with the particular propeller maker for their recommended torque values as they will vary with each maker. In any case, the torque must not exceed the rated value for the bolts. Example: 7/16" bolts can be torqued up to 400-450 in/lbs, and 1/2" bolts to 550-600 in/lbs.

The torque technique is to rotate around the six bolt pattern such that you torque opposite bolt pairs. Once you've established the torque setting, go around and recheck each bolt again.

6. Safety wire the prop bolts using preferably 0.041" safety wire through the bolt head roll pins.

LANCAIR® 320FB

21-62

Chapter 21

REV.

0 / 11-1-91

ENGINE INSTALLATION - LYCOMING

7. After the first twenty (20) hours of flight the prop must be torque checked again. Subsequent checks should be made per the manufacturer's recommendations.



21-63

Chapter 21
ENGINE INSTALLATION - LYCOMING

REV. 0 / 11-1-91



M. Propeller, WOOD, FIXED-PITCH

Lancair 320's are designed for use with a constant speed prop, but wood fixed-pitch props can be used (but you will have to get weight forward, i.e., battery next to firewall, etc.).

1. If you use a wood prop, you must use a 4" prop extension (see figure 21-36). This will attach directly to the prop flange. Be sure that the flange and aft face of the extension are clean, as dirt under the extension will throw the prop out of alignment.
2. The AN6 prop extension mounting bolts must be safety wired through the heads. Torque values are 220-265 in/lbs for 3/8" bolts.
3. Next slip the spinner backup plate over the extension, again making sure that all surfaces are clean. Position the starter ring assembly in the motor flange, observing alignment of the oversized lug, to properly orient your timing mark.
4. Position the propeller by gently tapping on the hub section. The drive lugs often pose a snug fit into the prop hub so very gentle, back and forth, tapping is usually necessary.
5. Once the prop is started on, position the crush plate (**a crush plate is mandatory on wood props**) and insert the prop bolts. The prop can then be snugged up by carefully tightening the bolts in a cross-rotation manner such that the prop is always kept 'square' to the flange. **DO NOT ALLOW THE PROP TO GET OUT OF SQUARE, THE DRIVE LUG HOLES IN THE PROP WOULD BECOME DAMAGED.**

To properly track the prop, remove the upper spark plugs from the engine so that it can be easily turned over by hand. Torque the bolts to no more than 10 inch/pounds. Position something under the prop tip at its lowest point to mark the point at which it passes. Turn the prop through 180°, and see where the other blade passes the mark. Snug the bolts to bring the prop square to the plate, i.e., tighten the bolts on the side of the blade that passes the farthest forward. Keep tightening and checking, using no more than 25 inch/pounds until prop is running true and fully snugged down.

6. With the prop snugged up, the proper torque must be established on the prop bolts.

THIS PROP TORQUE SETTING IS CRITICAL TO SAFE OPERATIONS.

You'll have to check with the particular propeller maker for their recommended torque values as they will vary with each maker. In any case, the torque must not exceed the rated value for the bolts. Example: The Great American Propeller can be torqued up to 16 ft/lbs or 192 in/lbs.

The torque technique is to rotate around the six bolt pattern such that you torque opposite bolt pairs. Once you've established the torque setting, go around and recheck each bolt again.



7. Safety wire the prop bolts using preferably 0.040" safety wire through the bolt heads.
8. After the first half hour (30 minutes) of flight, the prop **MUST** be retorqued. The prop finish will usually crush a little thus lowering the torque values which were first set.
9. After the first ten (10) hours of flight the prop must be torque checked again. Subsequent checks should be made per the manufacturer's recommendations.



21-65

Chapter 21	REV.	0 / 11-1-91
ENGINE INSTALLATION - LYCOMING		



PROPELLER EXTENSION / PROP / SPINNER ASSEMBLY

For fixed pitch prop - side view

Figure 21-36

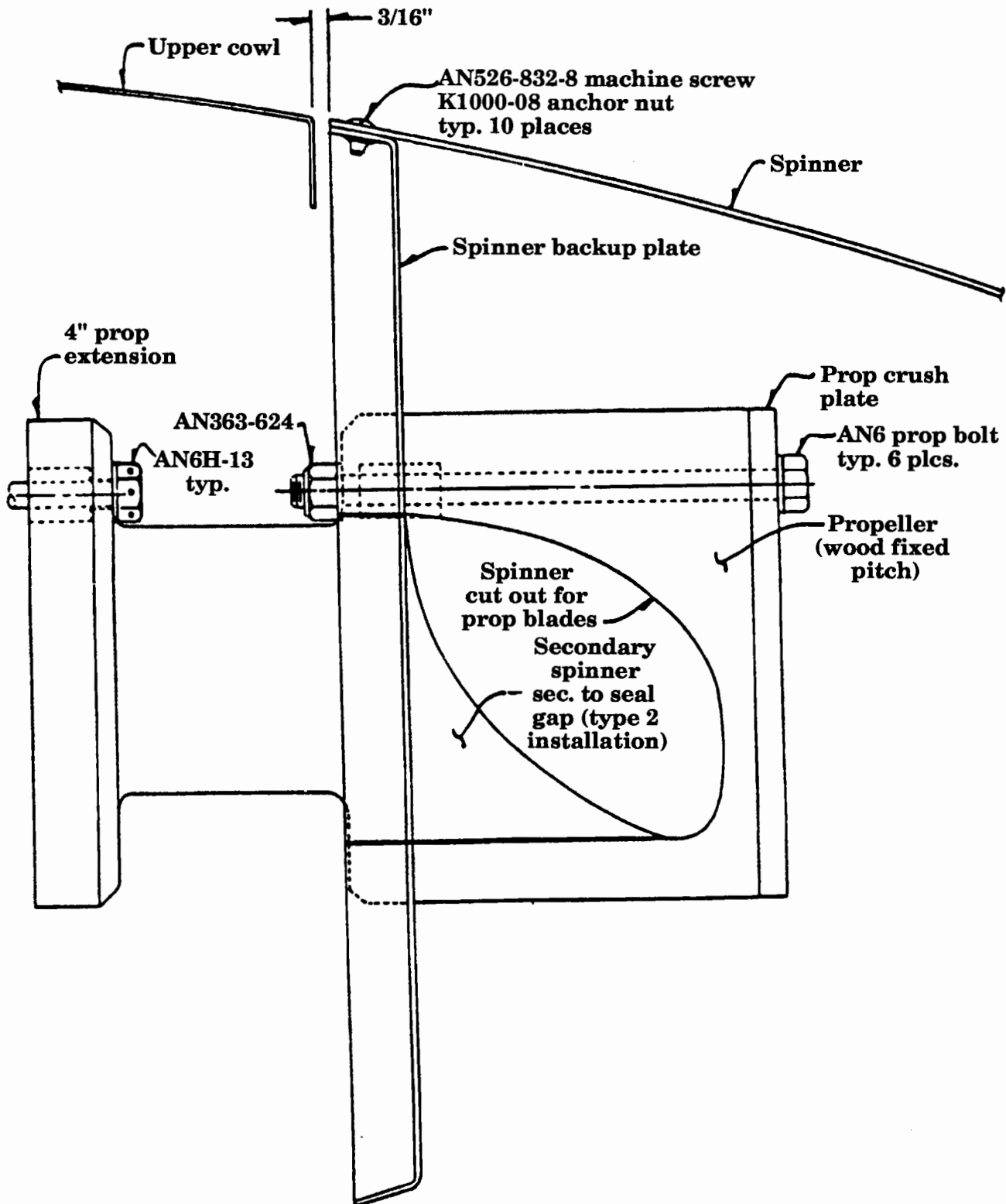

N. Spinner

1. If you do not have a template for the prop blade cut out within the spinner, one will have to be made. Neico does have many templates available for various props.

You can make a pattern out of paper through a fit and check method using light carton board. Once a template is established, it must be transferred to the spinner by tracing a line with a pencil or pen. Be sure to allow for the thickness of the backup plate which is generally $3/4$ ". Also be sure to position the template in the correct 'direction' on the spinner. You wouldn't be the first to make a beautiful cutout only to find that it will work *only* on a pusher plane!

NOTE: Constant speed props change pitch during operation - be sure your cutout includes space for the prop's pitch swing. There are two approaches to making the cutout shape. The first is perhaps the easiest but it leaves a rather sizeable gap between prop and spinner on the leading edge side. The other is a little more involved but generates a nice, consistently small, gap. They are both illustrated in figure 21-37. Figure 21-38 has a full-size template for the Neico spinner for a Hartzell 2 blade prop.

2. One acceptable method of cutting out the prop clearance in the spinner is with a hand sabre saw and a fine tooth blade. You will have to hold the spinner very firmly as you cut and support the spinner well close to the cutting line otherwise the whole thing will begin to jump up and down with the saw movements. Use a narrow chord blade so the radius can be cut smoothly. If you have trouble cutting around the fwd radius, cut short of the final mark and file to finish.
3. With the prop cutout completed and leaving at least $3/32$ " clearance all around the blade, the spinner is ready for mounting. Bolt the spinner backup plate to the propeller, installing the spacers evenly between the plate and the prop.
4. The best way to check that the spinner is correct is to rotate the engine and measure against a fixed pointer for spinner tip concentricity.

Place the spinner into position and secure with tape. Remove the upper spark plugs from the engine so you can spin it by hand without fighting compression. Place a fine tipped felt marker in a fixed position such that it just clears the forward tip of the spinner when positioned at the side. Turn the prop gently so as not to rock the plane and check for spinner concentricity. If it is out of alignment, the marker will mark a line at the point that is too far out from the center line. Adjust and recheck until the marker maintains equal clearances all the way through one revolution.

SPINNER CUTOUT

Figure 21-37

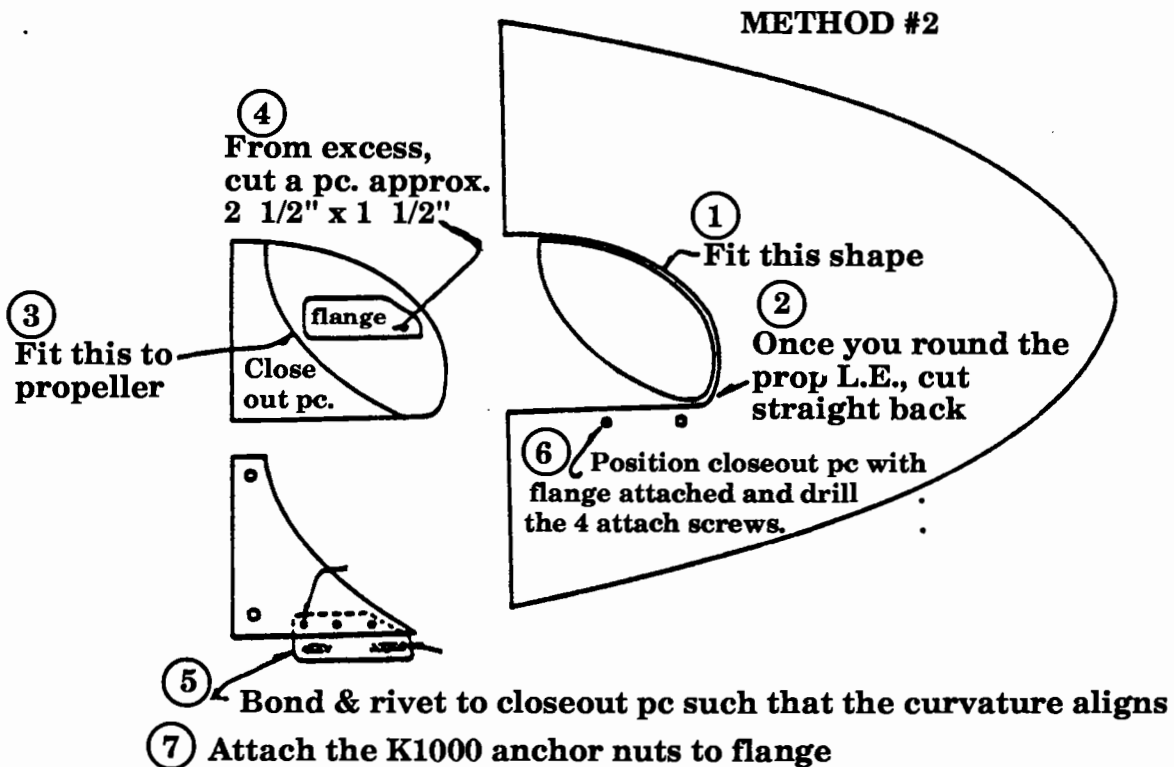
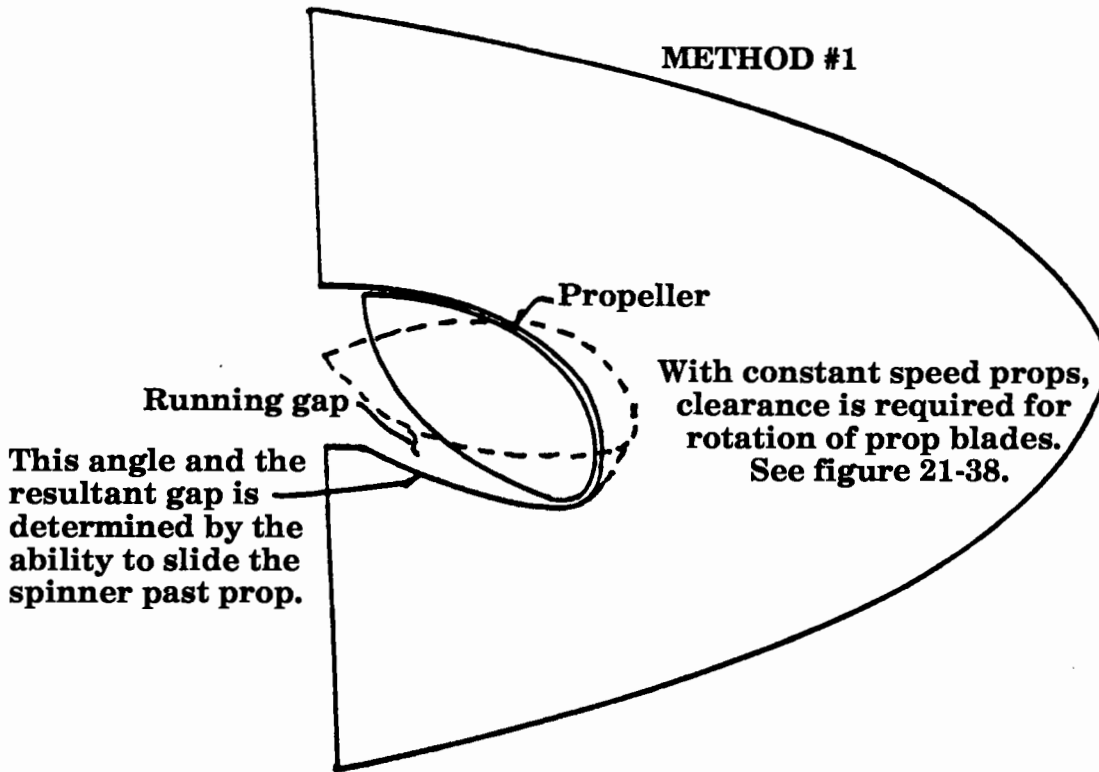

Another easier way (which is less accurate) is generally acceptable. Check for a scribe line on the aft edge of the spinner along the outside. If there is no scribe line, it can be assumed that the spinner is in fact trimmed exactly to the scribe line already. If you see any portion of the scribe line, sand lightly until a uniform distance is achieved or if only one side of the spinner shows a scribe line, sand until it is removed. This will then provide a 'true' spinner Trailing Edge. The T.E. can then be aligned with the T.E. of the back up plate and thus establish concentricity. This technique, although not truly 'exact' does seem to achieve satisfactory results when carefully performed.

5. With the spinner now ready for permanent attachment, secure in position (preferably with clamps).
6. The spinner should be attached with five (5) AN526-832-8 machine screws per side (AN526-1032-8 can also be used). Mark the locations along the circumference and mark the centers at approximately 0.350 fwd of the backup plate T.E.
7. Drill the center holes first using the appropriate bit (#19 for 832 or #12 for 1032). It is best to now place a temporary screw and plain nut through these holes. The remaining four screws per side should be drilled from center first moving outward towards the prop blades. Secure the spinner as you drill. In this manner, there will not be any 'buckling' tendency since the fit is 'worked out from the center'.
8. With all ten attachment holes drilled, remove the spinner and attach the K-1000 anchor nuts to the backup plate.
9. If you have chosen the second type of prop cutout, then the secondary gap filler must be added, see figure 21-37 Method 2. It will require 2 additional attachment screws on the backup plate and two along the spinner side (by the prop blade).

Make the overlapping attachment segment from a section of the piece cut out for the prop. Bond and rivet this piece to the filler piece with epoxy and three AN426-3-5 flat head rivets.



Hartzell 2 blade spinner cut-out template

Figure 21-38

FULL SIZE

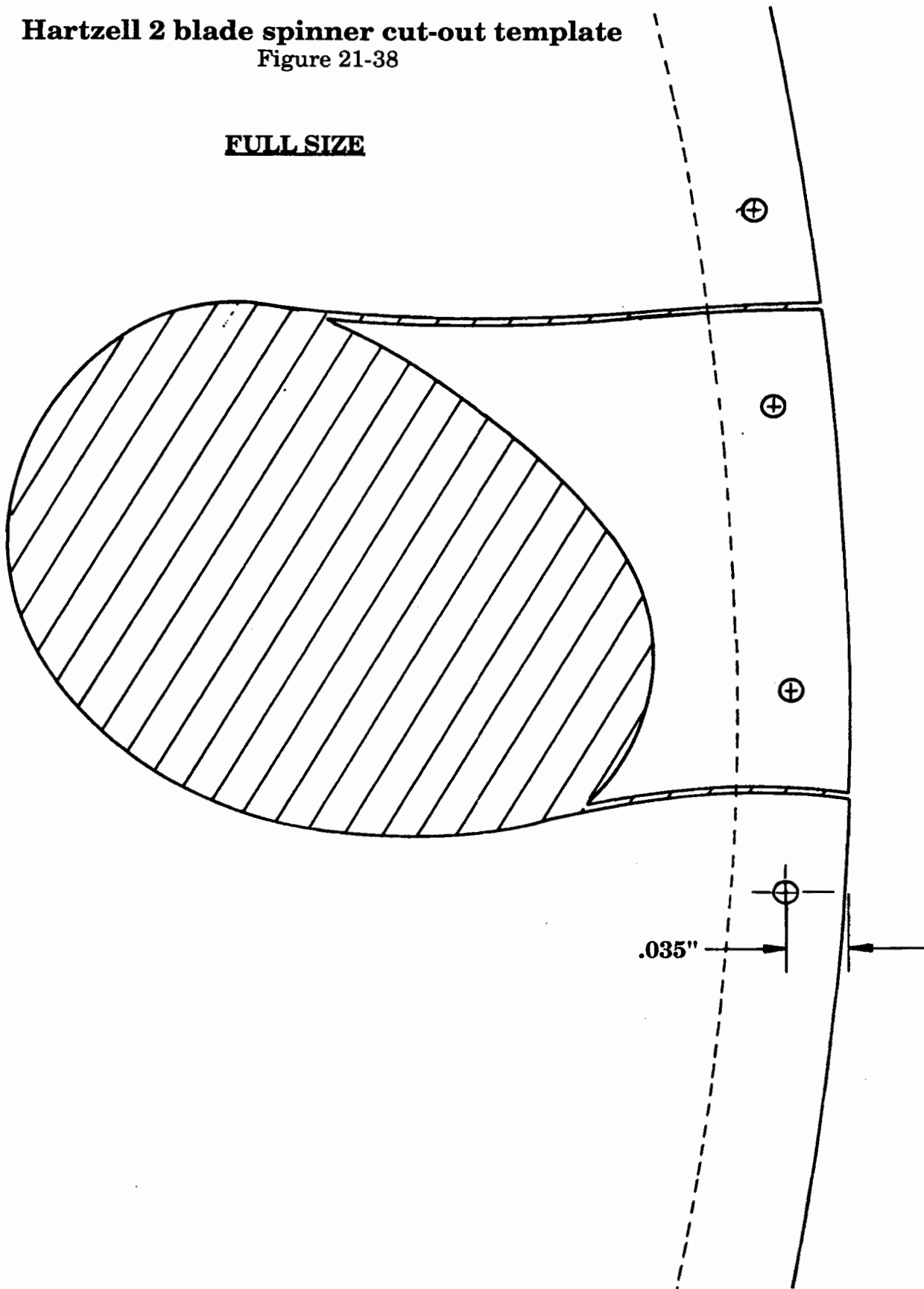

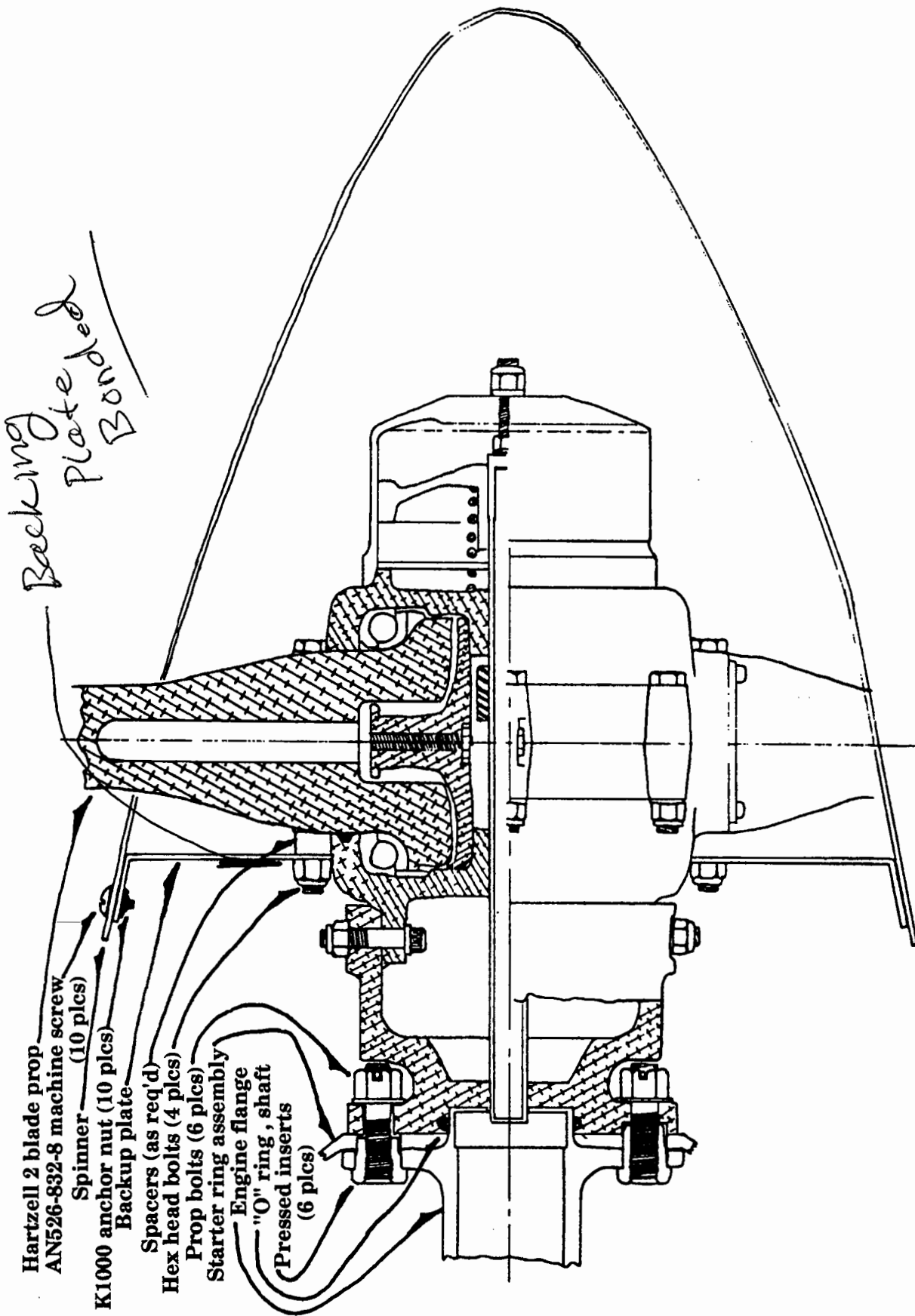

Hartzell 2 blade prop and spinner assembly
Figure 21-39

O. Tachometer

If you intend to use an electric tach then its location is not important beyond your personal preference. If you use a mechanical tach, there is one preferred location which allows for a good cable routing. This location is just right of the center radio stack, at the bottom of the panel, shown in figure 21-40. Generally a 40" tach cable works well but this will obviously be affected by your instrument panel FS location.



Mechanical tachometer location

Figure 21-40

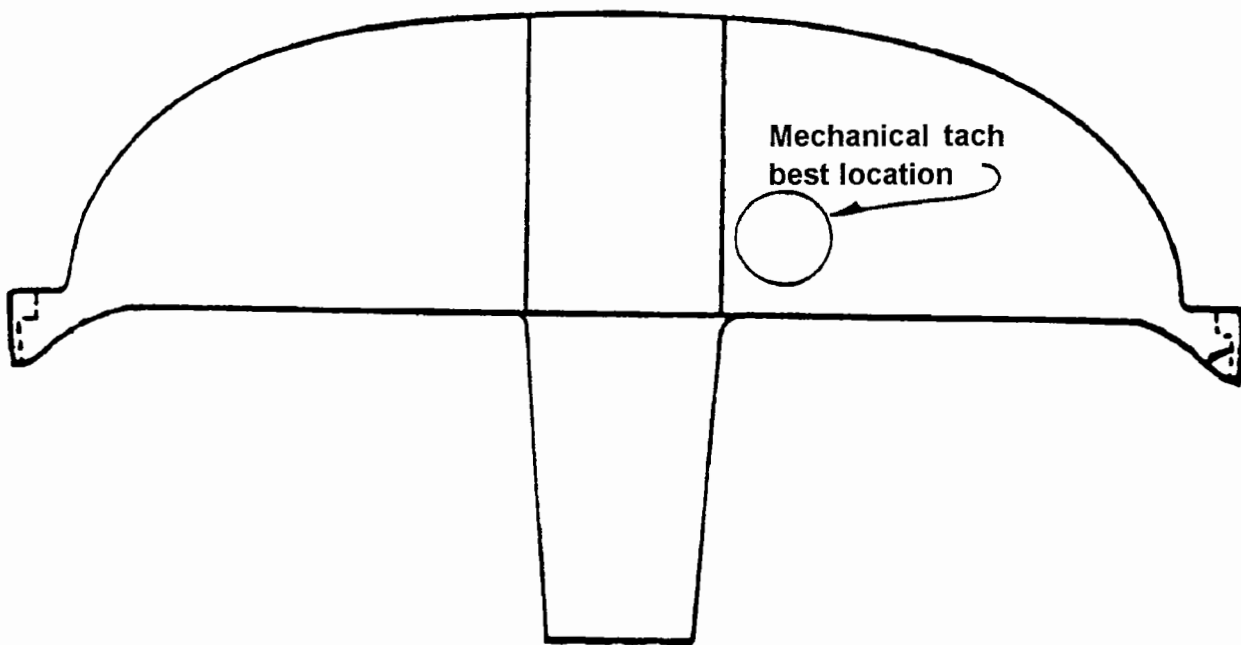



P. Miscellaneous Paperwork

It is important that you begin the registration process to receive your "N" number well in advance of completing your Lancair since this process can take up to three months to be completed. You will need to use the following FAA forms to complete this process:

- 8050-1 Aircraft Registration Application
- 8050-88 Affidavit of Ownership (you may use the one provided in this section)
- AC 8050-2 Aircraft Bill of Sale (if aircraft is purchased used)
- 8130-12 Notarized Eligibility Statement.

You should contact your local FAA Flight Standards District Office (FSDO) as some have developed packets which include all the paperwork needed for registration. You should also consult them on the application for the airworthiness certificate as they are very particular as to how this is to be filled out.

The builder of the aircraft may apply for a repairman certificate for his aircraft in accordance with FAR 65.104 using Advisory Circular AC65-23A. Having this certificate will allow the holder to maintain and repair the aircraft. This certificate may not, however, be transferred to another person if ownership of the aircraft should change in the future.

As you are going through the registration and inspection process, you may find it helpful to read both Advisory Circular 20-27D, Certification and Operation of Amateur-Built Aircraft, Advisory Circular 20-139, Commercial Assistance During Construction of Amateur-Built Aircraft, and Advisory Circular 90-89, Amateur-Built Flight Test Handbook.



21-73

Chapter 21	REV.	6/04-01-99	
MISCELLANEOUS			

The following instructions have been provided by the Federal Aviation Administration for identification number assignment and registration of amateur aircraft.



A U.S. identification number of the FAA's choice may be assigned, free of charge, to your amateur-built aircraft when you submit a complete description of the aircraft. The form titled "Affidavit of Ownership for Amateur-Built Aircraft" may be used as it meets the FAA requirements of both description and registration purposes. Authority to use a number assigned free of charge expires 90 days after the date it is issued unless the aircraft is registered within that period.

A U.S. identification number of your choice may be reserved, if available, for one year by sending a written request and a \$10 fee for each number to be reserved. Please list 5 numbers, in order of preference, in case your first choice is not available. If the number is not assigned to an aircraft prior to the end of the year, the reservation will expire, but may be renewed from year to year upon request and payment of a \$10 renewal fee.

NOTICE: The number may not be assigned or painted on an aircraft until approval is received from the FAA Registry Office.

Your written request to assign the reserved number to a particular aircraft must include a complete description of the aircraft. The "Affidavit" form may be used.

The items checked below are required to complete registration of your amateur-built aircraft:

Completed and signed Aircraft Registration Application

Registration fee of \$5.

Affidavit of Ownership, signed before a notary public, and showing a description of the aircraft. The "Affidavit" form meets FAA requirements and may be used if you wish.

Mail the completed documents and registration fee of \$5 to:

Federal Aviation Administration Aircraft Registry
Mike Monroney Aeronautical Center
P.O. Box 25504
Oklahoma City, OK 73125



21-74

Chapter 21	REV.	6/04-01-99
MISCELLANEOUS		



SAMPLE LETTER REQUESTING SPECIFIC N NUMBER



FAA Aircraft Registry
Department of Transportation
P.O. Box 25082
Oklahoma City, OK 73125

Gentlemen:

I request that a Special identification number be assigned to my amateur built aircraft.
This aircraft has not previously been registered anywhere.

Any of the following numbers would be acceptable (listed in order of preference):

- 1. N _____
- 2. N _____
- 3. N _____
- 4. N _____
- 5. N _____

Enclosed is my check for \$10 and an affidavit of ownership which describes the aircraft.

Sincerely,



Lancair International Inc. Copyright © 1999, Redmond, OR 97756

21-75

Chapter 21

REV. 6/04-01-99

MISCELLANEOUS



SAMPLE LETTER REQUESTING THE FAA ASSIGN N NUMBER

FAA Aircraft Registry
Department of Transportation
P.O. Box 25802
Oklahoma City, OK 73125

Gentlemen:

I request that a U.S. Identification number of your own choice be assigned to my amateur built aircraft.

An affidavit of ownership and description of the aircraft is enclosed. This aircraft has not previously been registered anywhere.

Sincerely,



21-76

Chapter 21 REV. 6/04-01-99
MISCELLANEOUS



AFFIDAVIT OF OWNERSHIP FOR AMATEUR-BUILT AIRCRAFT



U.S. Identification Number _____

Builder's Name _____

Model _____

Serial Number (required) _____

Class (airplane, rotorcraft, glider, etc.) _____

Type of Engine Installed _____

Manufacturer, Model, and Serial Number of each Engine Installed _____

Built for Land or Water Operation _____ Number of Seats _____

The above described aircraft was built from parts, and I am the owner.
Address _____

City _____ State _____ Zip Code _____

Telephone: Home () _____ Work _____

(Signature of Owner)

State of _____

County of _____

Subscribed and sworn to before me this _____ day of _____ 19 _____

My commission expires _____

(Signature of Notary Public)



21-77

Chapter 21	REV.	6/04-01-99
MISCELLANEOUS		



How to Register Your Lancair (in the United States)



There is a certain amount of paperwork which must be completed prior to the FAA doing a final inspection on your aircraft and issuing an airworthiness certificate. You may find the following definitions helpful when preparing your paperwork:

Airworthiness - The state or quality of an aircraft or of an aircraft component which will enable safe performance according to specifications.

Airworthiness Certificate - A document which shows that an aircraft meets the safety requirements of the FAA.

Registration Certificate - A document which must be displayed in a U.S. civil aircraft showing the owner as being registered with the FAA. An aircraft is eligible for registration only if it is owned by a citizen of the United States, and not registered under the laws of a foreign country.

Pilot's Operating Handbook - A handbook which typically gives information about the aircraft in the following areas:

- Aircraft Dimensions and Specifications
- Engine Specifications
- Limitations
- Emergency Procedures
- Normal Procedures
- Performance
- Weight and Balance
- Airplane and Systems Descriptions
- Airplane Handling, Service and Maintenance

This Pa - A record of the distribution of weight in an aircraft and the determination of the center of gravity (CG) at takeoff and landing.



21-78

Chapter 21

REV.

6/04-01-99

MISCELLANEOUS



Final Inspection Checklist



The purpose of this guide is to offer advice and guidance for the final inspection of the aircraft and to assist in the planning and preparation for flight testing your Lancair. You have invested many hours and much money in your aircraft, and all that can be lost in a matter of seconds without proper preparation and knowledge for the first flight.

Many requirements must be met prior to first flight. All FAA inspection(s), airworthiness certificate, registration, weight and balance, pilot qualification, placards, logbooks, restrictions, etc., should be completed prior to any testing. It is too easy to become airborne while taxi testing so do all the paperwork first. The EAA has many publications to assist in this preparation, and these are highly recommended.

We have assembled an exhaustive checklist to provide a system for checking all nuts, bolts, fittings, safety wire, cotter pins, systems, etc. Unlike a normal pre-flight inspection, this checklist follows a system-by-system approach. The intent is to make you think about the entire system that you are checking and to make certain that nothing has been overlooked.

Whatever you do, the most important thing to do is think. While you are inspecting a system (flight controls, for example) think about what the system is supposed to do. Look for any reason that the system might not function as intended.

While no checklist can ensure that you built the aircraft correctly, there are certain things that should be paramount in your mind. Cotter pins and safety wire are incredibly important. They are tiny things that are always a pain-in-the-rear to install, so it is quite possible that you did not install all of them. A missing cotter pin is an accident looking for a time to happen. Over the history of aviation there have already been way too many pilots and aircraft that have come to grief because a cotter pin was left out; don't add your name and N number to the list.

A review of the statistics of accidents involving experimental aircraft shows that engine failures play a role in one out of three, and fuel system problems are most often cited as the cause. These problems include fuel contamination, obstructed fuel vents, fuel system leaks, and fuel mismanagement. Thus, you should exercise extreme care to ensure the proper operation of the fuel system before any flight is attempted. Even after the aircraft is in the air, you should stay within the gliding range of the airport until you have absolute confidence that the fuel system is working properly.

